

RD125

Dana 35, non C-clip, 30 SPL, 3.54 & UP

PARTS LIST

| ITEM # | QTY | DESCRIPTION | PART # | NOTES |
|--------|-----|-----------------------------------|----------|-------|
| 1 | 1 | SEAL HOUSING O-RINGS (PK OF 2) | 160235SP | 1 |
| 2 | 1 | SEAL HOUSING KIT | 081801SP | |
| 3 | 2 | SHIM KIT | SHK003 | |
| * | 2 | MASTER SHIM | 150325 | |
| 4 | 1 | BONDED SEAL | 160701SP | |
| 5 | 1 | CLUTCH GEAR & WAVESPRING KIT | 050903SP | |
| 6 | 1 | SPIDER BLOCK | 070503SP | |
| 7 | 1 | LONG CROSS SHAFT | 061302SP | |
| 8 | 1 | SIDE GEAR | SEE NOTE | 3 |
| 9 | 1 | COUNTERSUNK SCREW (PK OF 2) | 200213SP | |
| 10 | 1 | RETAINING PIN SET (PK OF 4) | 120601SP | |
| 11 | 2 | TAPERED ROLLER BEARING | 160109 | 2 |
| 12 | 1 | FLANGE CAP KIT | 028504SP | |
| 13 | 1 | WAVESPRING | 150702SP | |
| 14 | 1 | SPLINED SIDE GEAR | SEE NOTE | 3 |
| 15 | 2 | SHORT CROSS SHAFT | 061402SP | |
| 16 | 4 | PINION GEAR | SEE NOTE | 3 |
| 17 | 4 | PINION THRUST WASHER | SEE NOTE | 4 |
| 18 | 2 | SIDE GEAR THRUST WASHER | SEE NOTE | 4 |
| 19 | 1 | DIFFERENTIAL CASE | 013106SP | |
| * | 1 | BULKHEAD FITTING KIT (BANJO TYPE) | 170114 | 5 |
| * | 1 | AIR LINE (6mm DIA X 6m LONG) | 170314SP | 5 |
| * | 1 | SOLENOID VALVE (12V) | 180103 | |
| * | 1 | SWITCH | 180209SP | |
| * | 1 | SWITCH COVER (REAR) | 180211SP | |
| * | 1 | CABLE TIE (PK OF 25) | 180305 | |
| * | 1 | OPERATING & SERVICE MANUAL | 210200 | |
| * | 1 | INSTALLATION GUIDE | 2102125 | |

* *Not illustrated in exploded view*

NOTES

- 1 For replacement O-rings use only BS133 Viton 75.
- 2 For replacement bearing use Timken part # LM501349 / LM501310.
- 3 Available only as complete 6 gear set # 728J031
- 4 Available only as complete thrust washer kit #730J01
- 5 All diffs produced before #17070001 came with 4mm air connection system. For information contact ARB.
- Newer OEM Dana 35 ring and pinion sets use 7/16" bolts. The flange holes of the Air Locker must be reamed from Ø3/8" to Ø7/16" to suit.
- Some OEM Dana 35 drive pinion gears extend too far into the centre and converge with the differential carrier. Refer to ring and pinion modification note ([Section 5.6](#)) for correction.
- 30 spline Dana 35 is a performance upgrade requiring aftermarket axle shafts.

RD125

Dana 35, non C-clip, 30 SPL, 3.54 & UP

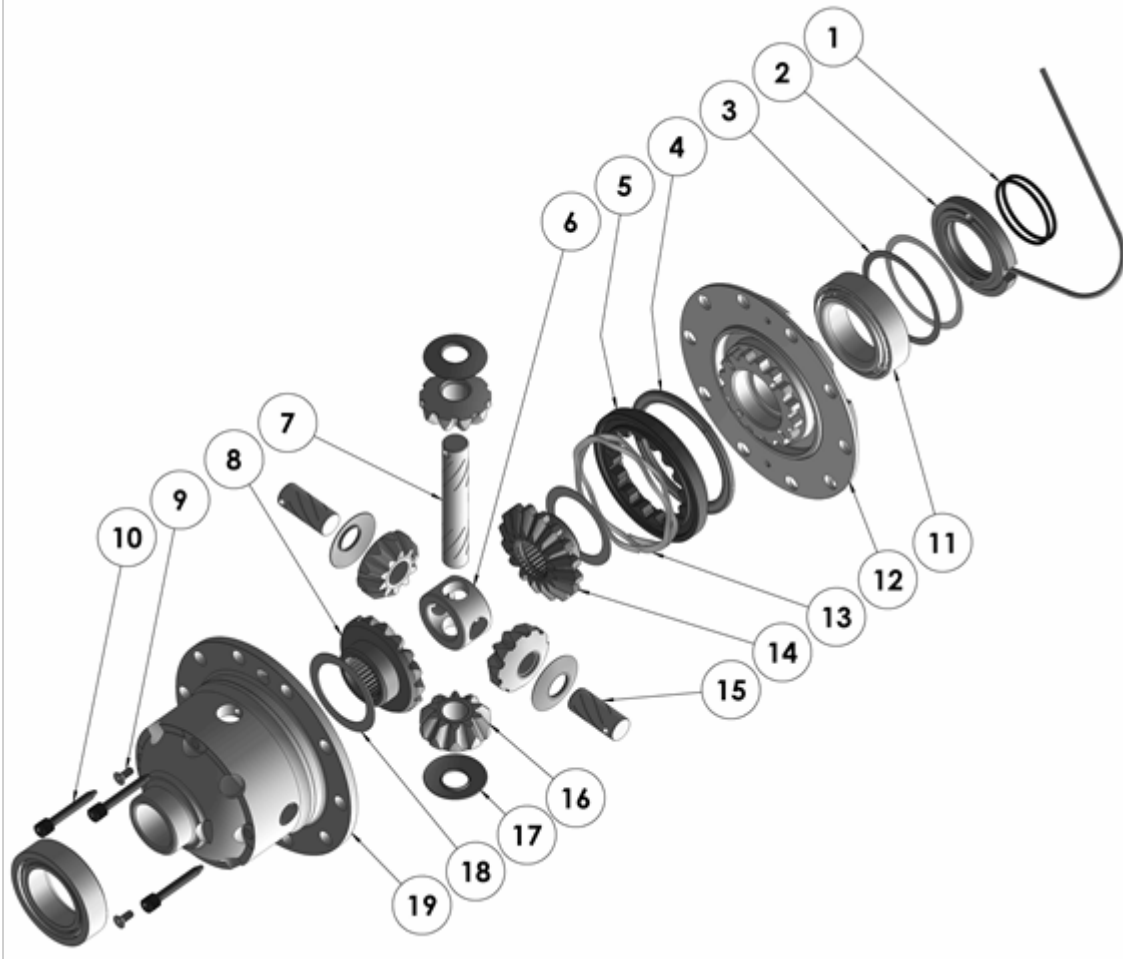
EXPLODED DIAGRAM**SPECIFICATIONS**

| | |
|--------------------|----------------------------|
| Axle Spline | 30 tooth, Ø33.3mm [1.31"] |
| Ratio Supported | 3.54:1 & up |
| Ring Gear ID | 120.7mm [4.75"] |
| Ring Gear OD | 193mm [7.6"] |
| Ring Gear Bolts | 8 bolts on Ø146mm [5.75"] |
| Ring Gear Torque | 75Nm [55 ft-lb] |
| Backlash | 0.15-0.25mm [0.006-0.010"] |
| Bearing Cap Torque | 75Nm [55 ft-lb] |

ARB Corporation Ltd • 42-44 Garden St Kilsyth VIC 3137 Australia
ARB 4X4 Accessories USA • 720 SW 34th St Renton WA 98057 USA
Australia & International Customer Service • +61 3 9761 6622
North America Customer Service • Toll Free 866 293 9078
www.arb.com.au (AUS & Int) www.arbusa.com (N. America)

