

RD186

AMC 20, 3.08 & UP

PARTS LIST

ITEM #	QTY	DESCRIPTION	PART #	NOTES
1	1	FLANGE CAP KIT	027332SP	
2	1	BONDED SEAL	160702SP	
3	1	CLUTCH GEAR & WAVESPRING KIT	050906SP	
4	4	PINION THRUST WASHER	SEE NOTE	4
5	1	SPIDER BLOCK	070201SP	
6	1	THRUST BLOCK	110510SP	
7	1	SIDE GEAR	SEE NOTE	3
8	1	DIFFERENTIAL CASE	013032SP	
9	1	RETAINING PIN SET (PK OF 4)	120601SP	
10	1	SHIM KIT	SHK008	
11	1	TAPERED ROLLER BEARING	160109	2
12	1	SEAL HOUSING KIT	081501SP	
13	1	SEAL HOUSING O-RINGS (PK OF 2)	160227SP	1
14	1	WAVESPRING	150706SP	
15	1	LOCKING SIDE GEAR	SEE NOTE	3
16	4	SHORT CROSS SHAFT	060403SP	
17	4	PINION GEAR	SEE NOTE	3
18	2	SIDE GEAR THRUST WASHER	SEE NOTE	4
19	1	COUNTERSUNK SCREW (PK OF 2)	200213SP	
*	1	BULKHEAD FITTING KIT (BANJO TYPE)	170114	5
*	1	AIR LINE (6mm DIA X 6m LONG)	170314	5
*	1	SOLENOID VALVE (12V)	180103	
*	1	SWITCH	180209SP	
*	1	SWITCH COVER (FRONT)	180210SP	
*	1	SWITCH COVER (REAR)	180211SP	
*	1	CABLE TIE (PK OF 25)	180305	
*	1	OPERATING & SERVICE MANUAL	210200	
*	1	INSTALLATION GUIDE	2102186	

* *Not illustrated in exploded view*

NOTES

- 1 For replacement O-rings use only BS138 Viton 75.
- 2 For replacement bearing use Timken part # LM102949 / LM102910
- 3 Available only as complete 6 gear set # 728H231
- 4 Available only as complete thrust washer kit #730H01
- 5 All diffs produced before serial #17070001 came with 5mm air connection system. For information contact ARB.
- For ratios of 2.73:1 and down refer to RD187 ([Section 2.187](#)).

RD186

AMC 20, 3.08 & UP

EXPLODED DIAGRAM

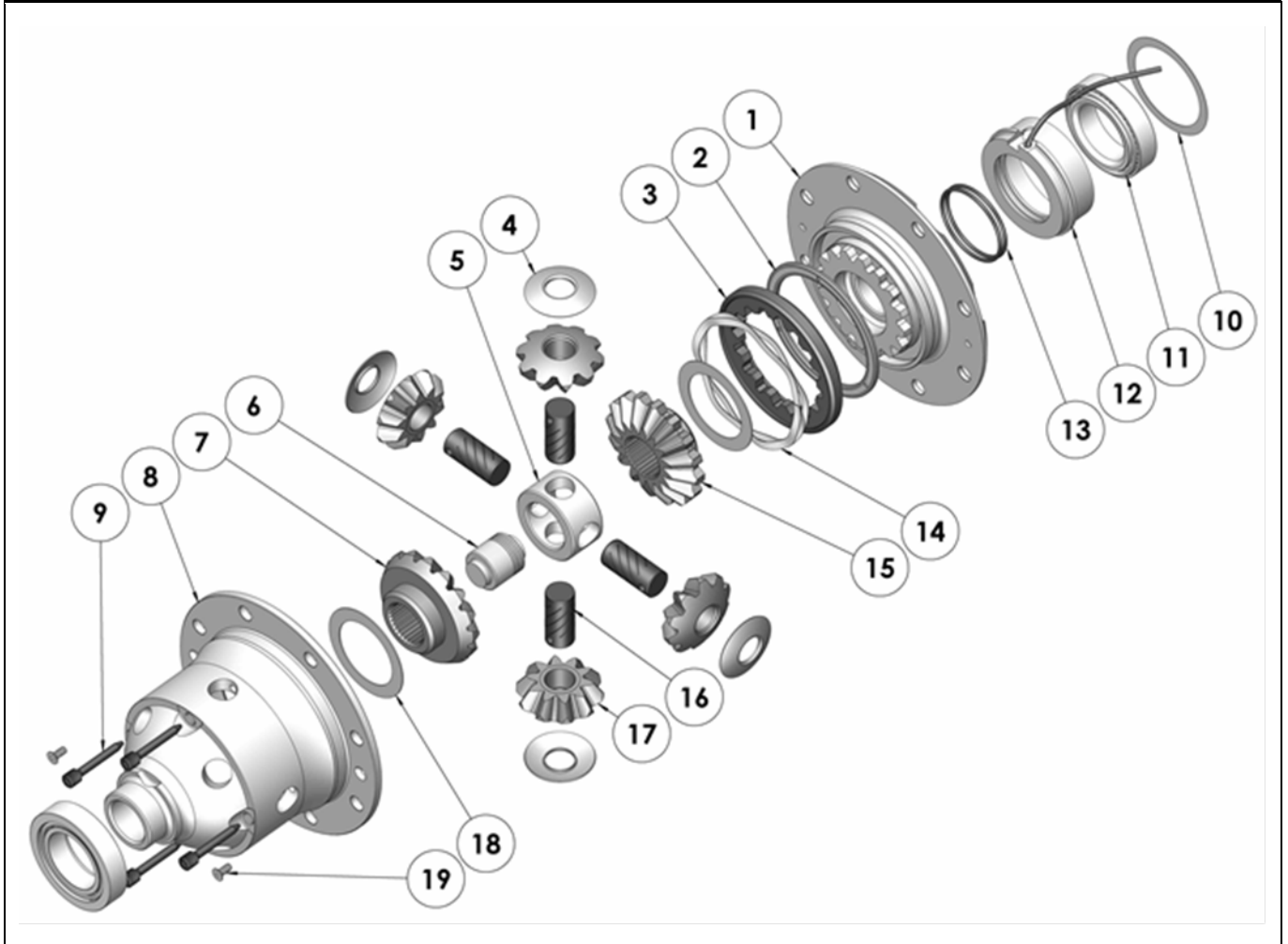

SPECIFICATIONS

Axle Spline	29 tooth, Ø31.5mm [1.24"]
Ratio Supported	3.08:1 & UP
Ring Gear ID	136.6mm [5.38"]
Ring Gear OD	225.6mm [8.88"]
Ring Gear Bolts	8 bolts on Ø165.00mm [6.49"]
Ring Gear Torque	88Nm [65 ft-lb]
Backlash	0.15-0.25mm [0.006-0.010"]
Bearing Cap Torque	88Nm [65 ft-lb]

ARB Corporation Ltd ▪ 42-44 Garden St Kilsyth VIC 3137 Australia
 ARB 4X4 Accessories USA ▪ 720 SW 34th St Renton WA 98057 USA
 Australia & International Customer Service ▪ +61 3 9761 6622
 North America Customer Service ▪ Toll Free 866 293 9078
 www.arb.com.au (AUS & Int) www.arbusa.com (N. America)

