

RD213

Isuzu,RR,26 SPL

PARTS LIST

ITEM #	QTY	DESCRIPTION	PART #	NOTES
1	1	FLANGE CAP KIT	027335SP	
2	1	BONDED SEAL	160702SP	
3	1	CLUTCH GEAR & WAVESPRING KIT	050906SP	
4	4	SHORT CROSS SHAFT	060403SP	
5	1	SIDE GEAR	SEE NOTE	2
6	2	SIDE GEAR THRUST WASHER	SEE NOTE	3
7	1	COUNTERSUNK SCREW (PK OF 2)	200213SP	
8	1	RETAINING PIN SET (PK OF 4)	120601SP	
9	*	TAPERED ROLLER BEARING	NOT SUPPLIED	
10	1	SHIM KIT	SHK005	
*	1	MASTER SHIM	150341	
11	1	SEAL HOUSING KIT	081813SP	
12	1	SEAL HOUSING O-RINGS (PK OF 2)	160207SP	1
13	1	WAVESPRING	150706SP	
14	1	SPLINED SIDE GEAR	SEE NOTE	2
15	4	PINION GEAR	SEE NOTE	2
16	4	PINION THRUST WASHER	SEE NOTE	3
17	1	SPIDER BLOCK	070201SP	
18	1	THRUST BLOCK	110511SP	
19	1	DIFFERENTIAL CASE	013035SP	
*	1	BULKHEAD FITTING (BANJO TYPE)	170114	4
*	1	AIR LINE (6mm DIA X 6m LONG)	170314SP	4
*	1	SOLENOID VALVE (12V)	180103	
*	1	SWITCH	180209SP	
*	1	SWITCH COVER (REAR)	180211SP	
*	1	CABLE TIE (PK OF 25)	180305	
*	1	OPERATING & SERVICE MANUAL	210200	
*	1	INSTALLTION GUIDE	2102213	

* *Not illustrated in exploded view*

NOTES

- 1 For replacement O-rings use only BS136 Viton 75
- 2 Available only as complete 6 gear set # 728H261
- 3 Available only as complete thrust washer kit #730H01
- 4 All diffs produced before serial #17070001 came with 5mm air connection system. For information contact ARB.

RD213

Isuzu,RR,26 SPL

EXPLODED DIAGRAM

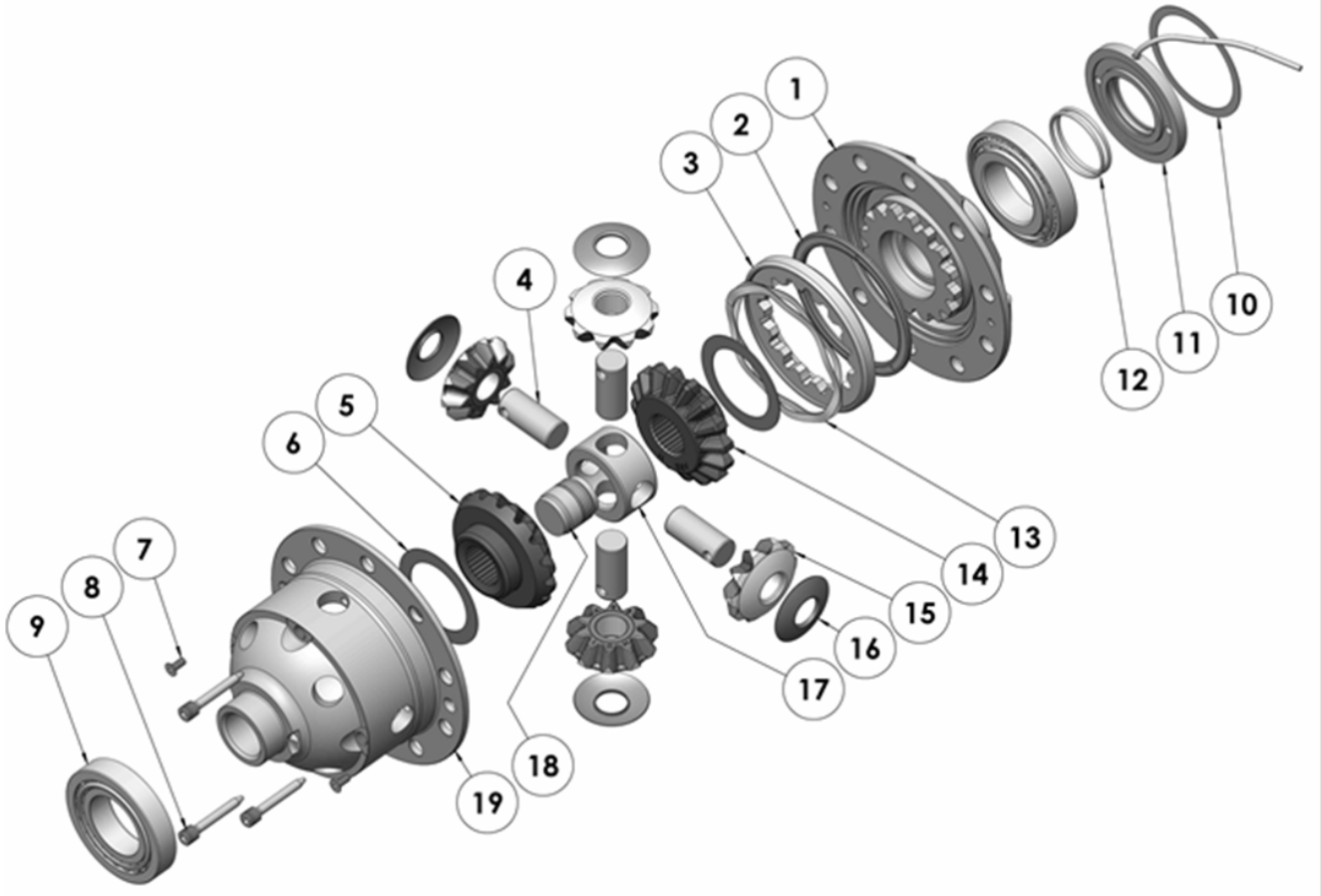

SPECIFICATIONS

Axle Spline	26 tooth, Ø33.5mm [1.32"]
Ratio Supported	All
Ring Gear ID	138.0mm [5.43"]
Ring Gear OD	12 bolts on Ø165mm [6.50"]
Ring Gear Bolts	10mm
Ring Gear Torque	108 Nm [80 ft-lb]
Backlash	0.15-0.20mm [0.006-0.008"]
Bearing Cap Torque	108 Nm [80 ft-lb]

ARB Corporation Ltd • 42-44 Garden St Kilsyth VIC 3137 Australia
ARB 4X4 Accessories USA • 720 SW 34th St Renton WA 98057 USA
Australia & International Customer Service • +61 3 9761 6622
North America Customer Service • Toll Free 866 293 9078
www.arb.com.au (AUS & Int) www.arbusa.com (N. America)