

### RD140

### FORD 'Sterling', 10¼" & 10½", 35 SPLINE

#### PARTS LIST

ITEM #	QTY	DESCRIPTION	PART #	NOTES
01	1	SEAL HOUSING KIT	082105SP	
02	-	TAPERED ROLLER BEARING	NOT SUPPLIED	3
03	1	FLANGE CAP KIT	028611SP	
04	1	BONDED SEAL	160703SP	
05	1	CLUTCH GEAR & WAVESPRING KIT	050907SP	6
*	1	CLUTCH GEAR & RETURN SPRINGS KIT	050807SP	6
06	1	LONG CROSS SHAFT	061501SP	
07	2	SHORT CROSS SHAFT	061601SP	
08	2	SIDE GEAR THRUST WASHER	SEE NOTE	4
09	1	DIFFERENTIAL CASE (SUITS WAVESPRING ONLY)	013231SP	5
*	1	DIFFERENTIAL CASE (SUITS RETURN SPRINGS ONLY)	013211SP	5
10	1	COUNTERSUNK SCREW (PK OF 2)	200214SP	
11	1	RETAINING PIN SET (PK OF 4)	120601SP	
12	1	SEAL HOUSING O-RINGS (PK OF 2)	160248-2	1
13	1	SHIM KIT	SHK006	
14	1	WAVESPRING	150707SP	6
*	1	RETURN SPRINGS KIT	150107SP	6
15	1	SPLINED SIDE GEAR	SEE NOTE	2
16	4	PINION THRUST WASHER	SEE NOTE	4
17	4	PINION GEAR	SEE NOTE	2
18	1	SPIDER BLOCK	070402SP	
19	1	SIDE GEAR	SEE NOTE	2
*	1	BULKHEAD FITTING KIT (BANJO TYPE)	170114	7
*	1	AIR LINE (6mm DIA X 6m LONG)	170314	7
*	1	SOLENOID VALVE (12V)	180103	
*	1	SWITCH RR LOCKER	180224SP	
*	1	CABLE TIE (PK OF 25)	180305	
*	1	OPERATING & SERVICE MANUAL	210200	
*	1	INSTALLATION GUIDE	2102140	

\* *Not illustrated in exploded view*

#### NOTES

- 1 For replacement O-rings use only BS140 Viton 75.
- 2 Available only as complete 6 gear set # 728K121.
- 3 For replacement bearing use Timken part # 469 / 453X.
- 4 Available only as complete thrust washer kit #730K01.
- 5 Identify the spring type in your diff and order the correct diff case to replace.
- 6 Replace the spring and/or the corresponding clutch gear with the same type.  
*(If spring type is changed, a matching diff case must also be used. See item 09.)*
- 7 All diffs produced before serial #17070001 came with 5mm air connection system. For information contact ARB.
- Suitable for use with ABS tone ring.
- Ford 10.25" & 10.5" corporate Sterling model can be visually distinguished from a Dana Spicer model by the absence of a filler hole in the OE inspection cover.

**RD140**

FORD 'Sterling', 10¼" &amp; 10½", 35 SPLINE

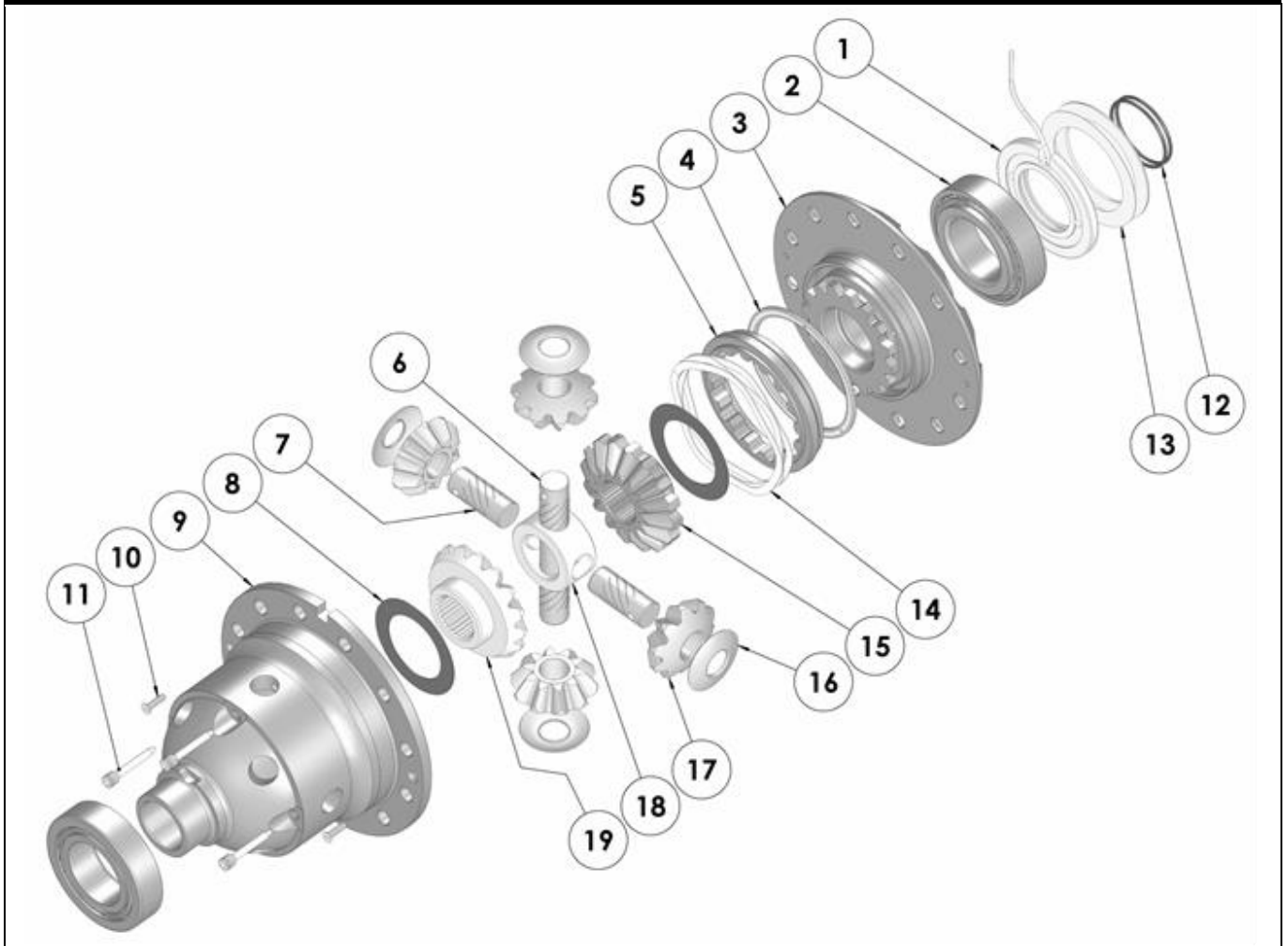
**EXPLODED DIAGRAM****SPECIFICATIONS**

Axle Spline	35 tooth, Ø38.1mm [1.50"]
Ratio Supported	All
Ring Gear ID	165.1mm [6.50"]
Ring Gear OD	260/268mm [10.25/10.50"]
Ring Gear Bolts	12 bolts on Ø192mm [7.56"]
Ring Gear Torque	129Nm [95 ft-lb]
Backlash	0.28-0.41mm [0.011-0.016"]

ARB Corporation Ltd ▪ 42-44 Garden St Kilsyth VIC 3137 Australia  
ARB 4X4 Accessories USA ▪ 4810 D St. NW #103 Auburn WA 98001 USA  
Australia & International Customer Service ▪ +61 3 9761 6622  
North America Customer Service ▪ Toll Free 866 293 9078  
www.arb.com.au (AUS & Int) www.arbusa.com (N. America)