

**RD171**

Dana 70/80,32 SPL,High Speed

### PARTS LIST

ITEM #	QTY	DESCRIPTION	PART #	NOTES
1	2	TAPERED ROLLER BEARINGS	NOT SUPPLIED	
2	1	SEAL HOUSING O-RINGS (PK OF 2)	160251-2	1
3	1	SEAL HOUSING KIT	082107SP	3
4	1	SEAL HOUSING BRACKET	220212	
5	1	FLANGE CAP KIT	028617SP	3
6	4	PINION GEAR THRUST WASHER	SEE NOTE	4
7	4	PINION GEAR	SEE NOTE	2
8	1	SPLINED SIDE GEAR	SEE NOTE	2
9	1	SPIDER BLOCK	070402SP	
10	1	SIDE GEAR	SEE NOTE	2
11	2	SIDE GEAR THRUST WASHER	SEE NOTE	4
12	1	DIFFERENTIAL CASE	013217SP	3
13	1	RETAINING PIN SET (PK OF 4)	120601SP	
14	1	COUNTERSUNK SCREW (PK OF 2)	200214SP	
15	2	MASTER SHIM (OD Ø104.5)	150357	
*	2	MASTER SHIM (OD Ø95.8)	150331	
16	1	BONDED SEAL	160706SP	
17	1	CLUTCH GEAR & WAVESPRING KIT	050909SP	
18	1	WAVESPRING	150705SP	
19	2	SHORT CROSS SHAFT	061601SP	
20	1	LONG CROSS SHAFT	061501SP	
*	1	SHIM KIT (OD Ø104.5)	SHK006	
*	1	SHIM KIT (OD Ø95.8)	SHK001	
*	1	BULKHEAD FITTING KIT (BANJO TYPE)	170114	5
*	1	AIR LINE (6mm DIA X 6m LONG)	170314	5
*	1	SOLENOID VALVE (12V)	180103	
*	1	SWITCH FR OR RR LOCKER	180225SP	
*	1	CABLE TIE (PK OF 25)	180305	
*	1	OPERATING & SERVICE MANUAL	210200	
*	1	INSTALLTION GUIDE	2102171	

\* *Not illustrated in exploded view*

### NOTES

- 1 For replacement O-rings use only BS149 Viton 75.
- 2 Available only as complete 6 gear set # 728K101
- 3 Diffs built pre June 2014 (serial numbers before 14060001) have 082106 Seal Housing, 013213 Case, and 028613 Flange Cap.
- 4 Available only as complete thrust washer kit #730K01
- 5 All diffs produced before serial #17070001 came with 5mm air connection system. For information contact ARB.
- For Low Speed ratios please refer to RD170 ([Section 2.170](#))

**RD171**

Dana 70/80,32 SPL,High Speed

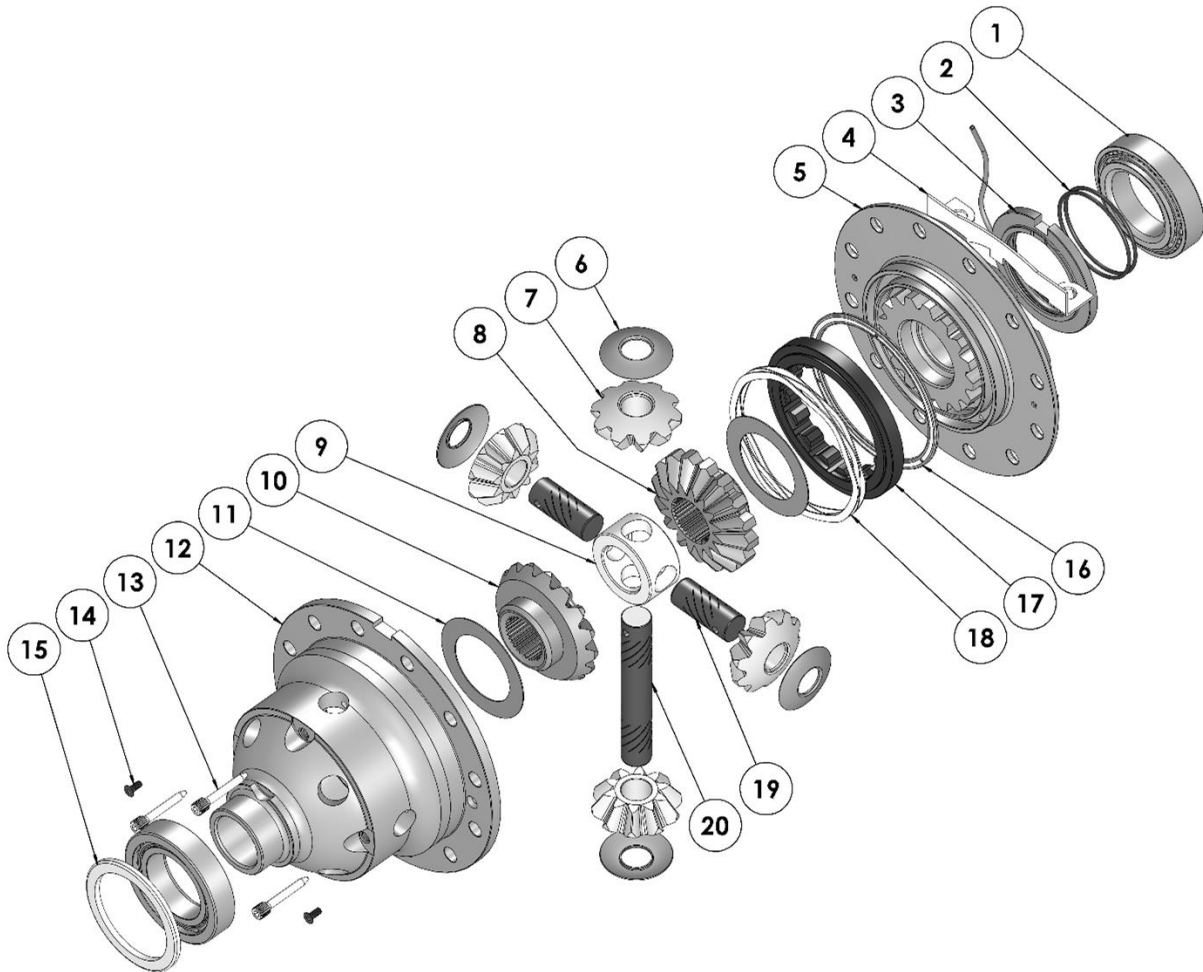
**EXPLODED DIAGRAM****SPECIFICATIONS**

Axle Spline	32 tooth, Ø35.8mm [1.41"]
Ratio Supported	Varies
Ring Gear ID	174.9mm [6.89"]
Ring Gear OD	267mm [10.5"]
Ring Gear Bolts	12 bolts on Ø203mm [8.00"]
Ring Gear Torque	149Nm [110 ft-lb]
Backlash	0.15-0.25mm [0.006-0.010"]
Bearing Cap Torque	108Nm [80 ft-lb]

ARB Corporation Ltd • 42-44 Garden St Kilsyth VIC 3137 Australia  
ARB 4X4 Accessories USA • 4810 D St. NW #103 Auburn WA 98001 USA  
Australia & International Customer Service • +61 3 9761 6622  
North America Customer Service • Toll Free 866 293 9078  
www.arb.com.au (AUS & Int) www.arbusa.com (N. America)

