

### RD193

Toyota 8" RR, 12 bolt RG, shim adjusted

### PARTS LIST

ITEM #	QTY	DESCRIPTION	PART #	NOTES
01	1	FLANGE CAP KIT	027328SP	
02	1	BONDED SEAL	160702SP	
03	1	CLUTCH GEAR & WAVESPRING KIT	050906SP	
04	1	SPLINED SIDE GEAR	SEE NOTE	2
05	1	LONG CROSS SHAFT	060204SP	
06	2	SHORT CROSS SHAFT	060403SP	
07	1	SIDE GEAR	SEE NOTE	2
08	1	DIFFERENTIAL CASE	013028SP	
09	1	SEAL HOUSING O-RINGS (PK OF 2)	160207-2	1
10	1	SHIM KIT	SHK009	
*	1	MASTER SHIM	150305	
11	1	SEAL HOUSING KIT	081814SP	
12	1	TAPERED ROLLER BEARING	NOT SUPPLIED	
13	1	WAVESPRING	150706SP	
14	4	PINION THRUST WASHER	SEE NOTE	3
15	4	PINION GEAR	SEE NOTE	2
16	1	SPIDER BLOCK	070201SP	
17	2	SIDE GEAR THRUST WASHER	SEE NOTE	3
18	1	RETAINING PIN SET (PK OF 4)	120601SP	
19	1	COUNTERSUNK SCREW (PK OF 2)	200213SP	
*	1	BULKHEAD FITTING KIT (BANJO TYPE)	170114	4
*	1	AIR LINE (6mm DIA X 6m LONG)	170314	4
*	1	SOLENOID VALVE (12V)	180103	
*	1	SWITCH RR LOCKER	180224SP	
*	1	CABLE TIE (PK OF 25)	180305	
*	1	OPERATING & SERVICE MANUAL	210200	
*	1	INSTALLATION GUIDE	2102193	

\* *Not illustrated in exploded view*

### NOTES

- 1 For replacement O-rings use only BS136 Viton 75.
- 2 Available only as complete 6 gear set # 728H111
- 3 Available only as complete thrust washer kit #730H01
- 4 All diffs produced before serial #17070001 came with 5mm air connection system. For information contact ARB.
- For 8" Toyota adjuster nut pre-loaded rear refer to RD132 ([Section 2.132](#)).

**RD193**

Toyota 8" RR, 12 bolt RG, shim adjusted

### EXPLODED DIAGRAM

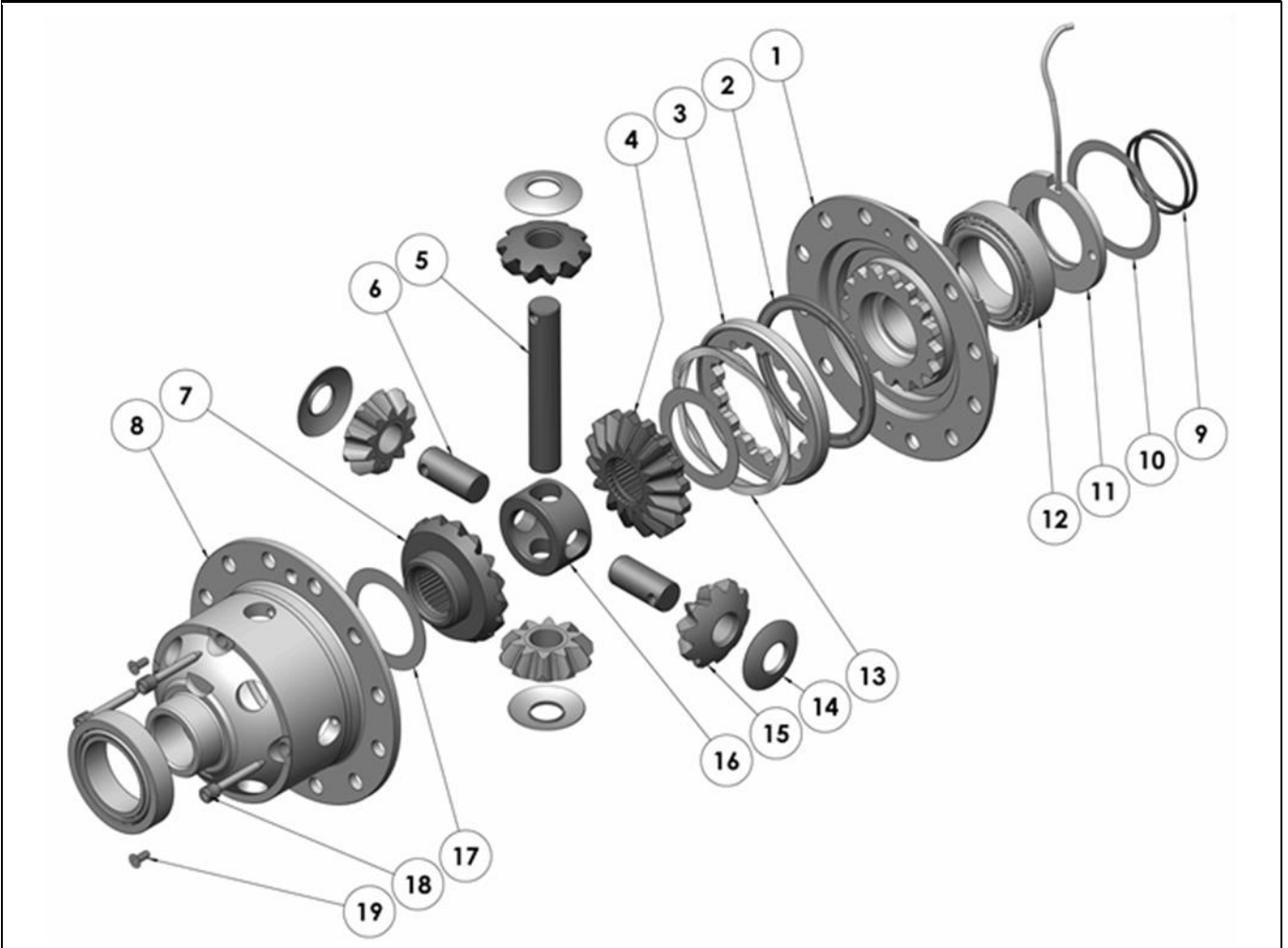

### SPECIFICATIONS

Axle Spline	30 tooth, Ø33mm [1.31"]
Ratio Supported	All
Ring Gear ID	125.98mm [4.96"]
Ring Gear OD	207mm [8.15"]
Ring Gear Bolts	12 bolts on Ø160.0mm [6.30"]
Ring Gear Torque	95Nm [70 ft-lb]
Backlash	0.15-0.25mm [0.006-0.010"]
Bearing Cap Torque	95Nm [70 ft-lb]