

RD99CE

Ford 9",35 SPL,2" BRNG

PARTS LIST

ITEM #	QTY	DESCRIPTION	PART #	NOTES
1	1	SEAL HOUSING O-RING (PK OF 2)	160207-2	1
2	1	LOCKING TAB KIT (PK of 10, incl M4 SCREWS)	LTK001	4
3	1	FLANGE CAP KIT	027339SP	
4	1	BONDED SEAL	160703SP	
5	1	CLUTCH GEAR & WAVESPRING KIT	050904SP	
6	1	SPLINED SIDE GEAR	SEE NOTE	2
7	4	PINION THRUST WASHER	SEE NOTE	5
8	4	PINION GEAR	SEE NOTE	2
9	1	SPIDER BLOCK	070903SP	
10	2	SPIDER BLOCK THRUST WASHER	SEE NOTE	5
11	1	SIDE GEAR	SEE NOTE	2
12	2	SIDE GEAR THRUST WASHER	SEE NOTE	5
13	1	SEAL HOUSING RETAINING CLIP	150601SP	
14	1	SEAL HOUSING KIT	081901SP	
15	1	ADJUSTER NUT	100105SP	
16	1	M4 X 12mm CAP SCREW (PK of 10, incl LOCK TABS)	LTK001	4
17	10	TRAC-LOK RING GEAR BOLT	NOT SUPPLIED	3
18	1	WAVESPRING	150704SP	
19	4	SHORT CROSS SHAFT	060403SP	
20	1	DIFFERENTIAL CASE	012207SP	
21	1	M5 CSK SCREW (PK OF 2)	200213SP	
22	1	RETAINING PIN (PK OF 4)	120701SP	
23	2	TAPERED ROLLER BEARING	160112	
*	1	BULKHEAD FITTING KIT (BANJO TYPE)	170114	6
*	1	AIR LINE (6mm DIA X 6m LONG)	170314	6
*	1	SOLENOID VALVE (12V)	180103	
*	1	SWITCH FR OR RR LOCKER	180225SP	
*	1	CABLE TIE (PK OF 25)	180305	
*	1	OPERATING & SERVICE MANUAL	210200	
*	1	INSTALLATION GUIDE	210299CE	

* *Not illustrated in exploded view*

NOTES

- 1 For replacement O-rings use only BS136 Viton 75.
- 2 Available only as complete 6 gear set # 728H281.
- 3 Use Trac-Lok LSD bolts with 5/8" head to suit.
- 4 Available only as complete kit.
- 5 Available only as complete thrust washer kit #730H02
- 6 All diffs produced before serial #17070001 came with 5mm air connection system. For information contact ARB.
- For the 31 spline Ford 9" refer to RD119 ([Section 2.119](#)).
- Refer to seal housing set-up tech note ([Section 5.2](#)).
- RD99CE does not suit the OEM third member. Aftermarket third member with carrier bearing ID of 50.80mm [2.000"] and a bearing thickness of 21.59mm [0.850"] must be used.

RD99CE

Ford 9",35 SPL,2" BRNG

EXPLODED DIAGRAM

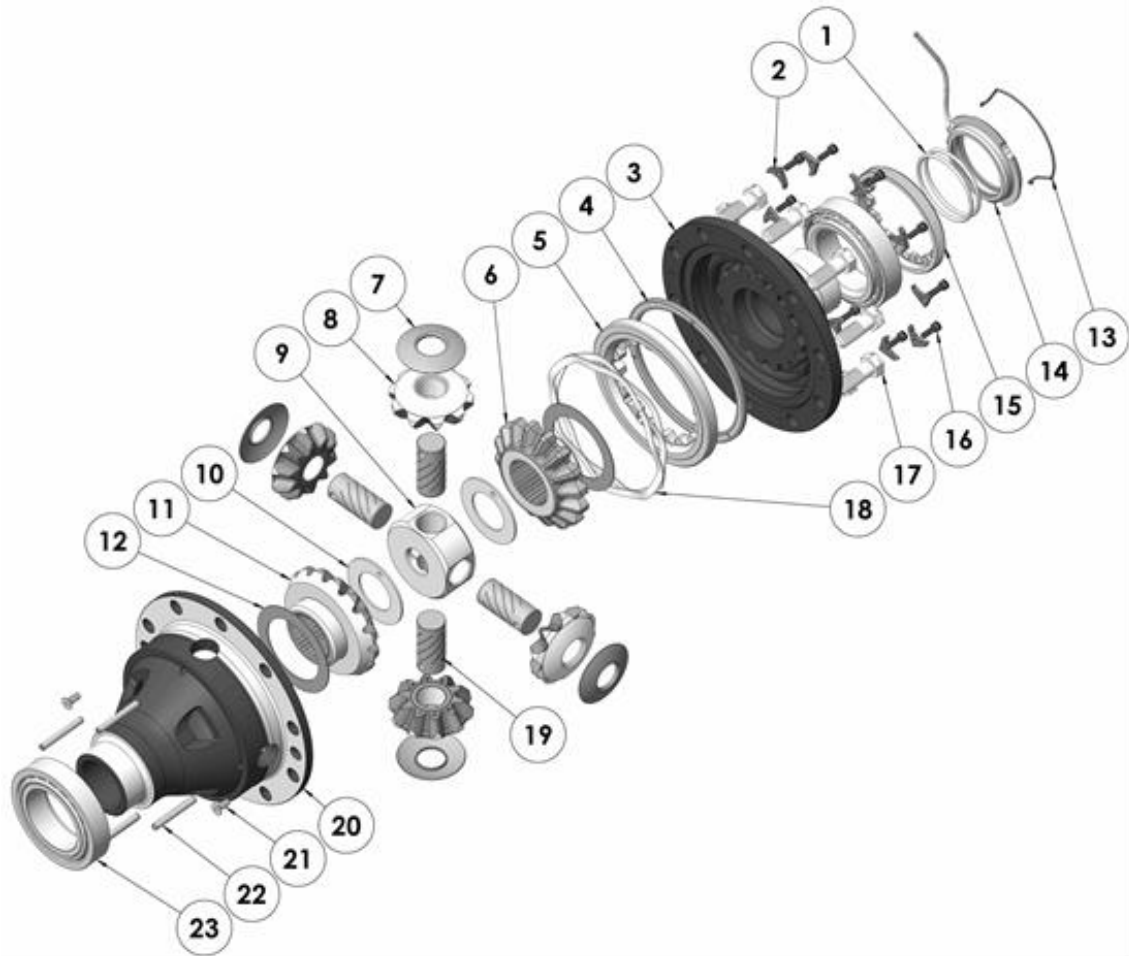

SPECIFICATIONS

Axle Spline	35 tooth, Ø38.1mm [1.50"]
Ratio Supported	All
Ring Gear ID	127.0mm [5.00"]
Ring Gear OD	229mm [9"]
Ring Gear Bolts	10 bolts on Ø152mm [6.00"]
Ring Gear Torque	95Nm [70 ft-lb]
OEM Backlash	0.25-0.41mm [0.010-0.016"]
Non-OEM Backlash	0.18-0.25mm [0.007-0.010"]
Bearing Cap Torque	81Nm [60 ft-lb]

ARB Corporation Ltd • 42-44 Garden St Kilsyth VIC 3137 Australia
ARB 4X4 Accessories USA • 4810 D St. NW #103 Auburn WA 98001 USA
Australia & International Customer Service • +61 3 9761 6622
North America Customer Service • Toll Free 866 293 9078
www.arb.com.au (AUS & Int) www.arbusa.com (N. America)

