

## CKMP12V2 Portable Compressor Kit

ITEM #	QTY	DESCRIPTION	PART #	NOTES
1	1	SAFETY VALVE FITTING	320204	1, 2
2	1	SAFETY VALVE SPRING	150115	1, 2
3	1	SAFETY VALVE POPPET	320205	1, 2
4	2	COMPRESSOR HEAD BOLT (M6 x 60)	200703	2
5	1	HEAD ASSEMBLY	320102	1
6	1	O-RING (BS031N70)	160241	2
7	1	MANIFOLD CAP	320236	
8	1	HOSE COUPLING (US STD FEMALE)	171402	
9	1	PRESSURE SWITCH (1/4" NPT)	180916	
10	1	O-RING (METRIC 6X2 N70)	160242	2
11	1	FLAT WASHER	6151046	2
12	1	MANIFOLD BOLT (M6 x 40)	6151584	2
13	1	HEAT SHIELD	320238	
14	1	PORTABLE COMPRESSOR SWITCH	180221SP	
15	2	BOLT (M6 x 10mm)	6151496	
16	1	BOLT, COACH HEAD (M6 x 16)	6151438	
17	1	RELAY, 12V, 40A, SEALED	180905	
18	1	FLANGE NUT (M6)	6151173	
19	1	MOUNTING BRACKET	320121	
20	4	SCREW COUNTERSUNK (M6 x 16)	6151231	
21	1	MOTOR ASSEMBLY (12V)	320104	
22	1	AXLE	320232	2
23	1	AXLE CAP SCREW (M6 x 25)	200718	2, 3
24	1	O-RING (BS029N70)	160250	2
25	1	AIR FILTER FLANGE (1/4" NPT)	320212	
26	2	BOLT (M6 x 10)	6151496	
27	1	AIR FILTER BASE	320501B	2
28	1	AIR FILTER ELEMENT DISC	290503	2
29	1	AIR FILTER COVER	320501A	2
30	1	PISTON ASSEMBLY (SERVICE KIT)	SEE NOTE	2
31	3	O-RING (BS032S70)	160247	2
32	1	BARREL	320201	2
33	1	VALVE PLATE ASSEMBLY	320105	2
*	1	WIRING LOOM	180410	
*	1	CARRY CASE	270201	
*	1	RETAINING RING, DIN7993 RW-14	6151767	2
*	1	HOSE	171301V2	
*	1	INFLATION ACCESSORY KIT	171303V2	
*	1	CARRY CASE POCKET	270108	

\* Not illustrated in exploded view.

### Specs:

Voltage	12 Volts
Current Draw	No-Load 13A Load 23A
Air Flow	75.1L/min @ 0kPa [2.65CFM @ 0psi] 61.6L/min @ 200kPa [2.18CFM @ 29psi]
Total Weight	7.0kg [15.4lbs]
Size	356 x 308 x 182 mm (L x W x H) [14.02 x 12.13 x 7.17]
Manifold Port	1/4" NPT [Pressure Switch] x 1
Pressure Switch	Open 690kPa [100psi] Closed 490kPa [70psi]
Safety Valve	OPEN @ > ~1250Kpa [180 PSI]

### Notes:

- 1 HEAD ASSY (5) comes pre-assembled with safety valve.
- 2 Included in Complete Overhaul Kit (P/N 180914)
- 3 Thread lock must be applied to threads of CAP SCREW (23) and then torqued to 13 Nm [9.6ft-lb].  
  
CAP SCREW (23) should never be re-used once it has been fully torqued once.



## CKMP12V2 Air Compressor – Exploded Parts Diagram

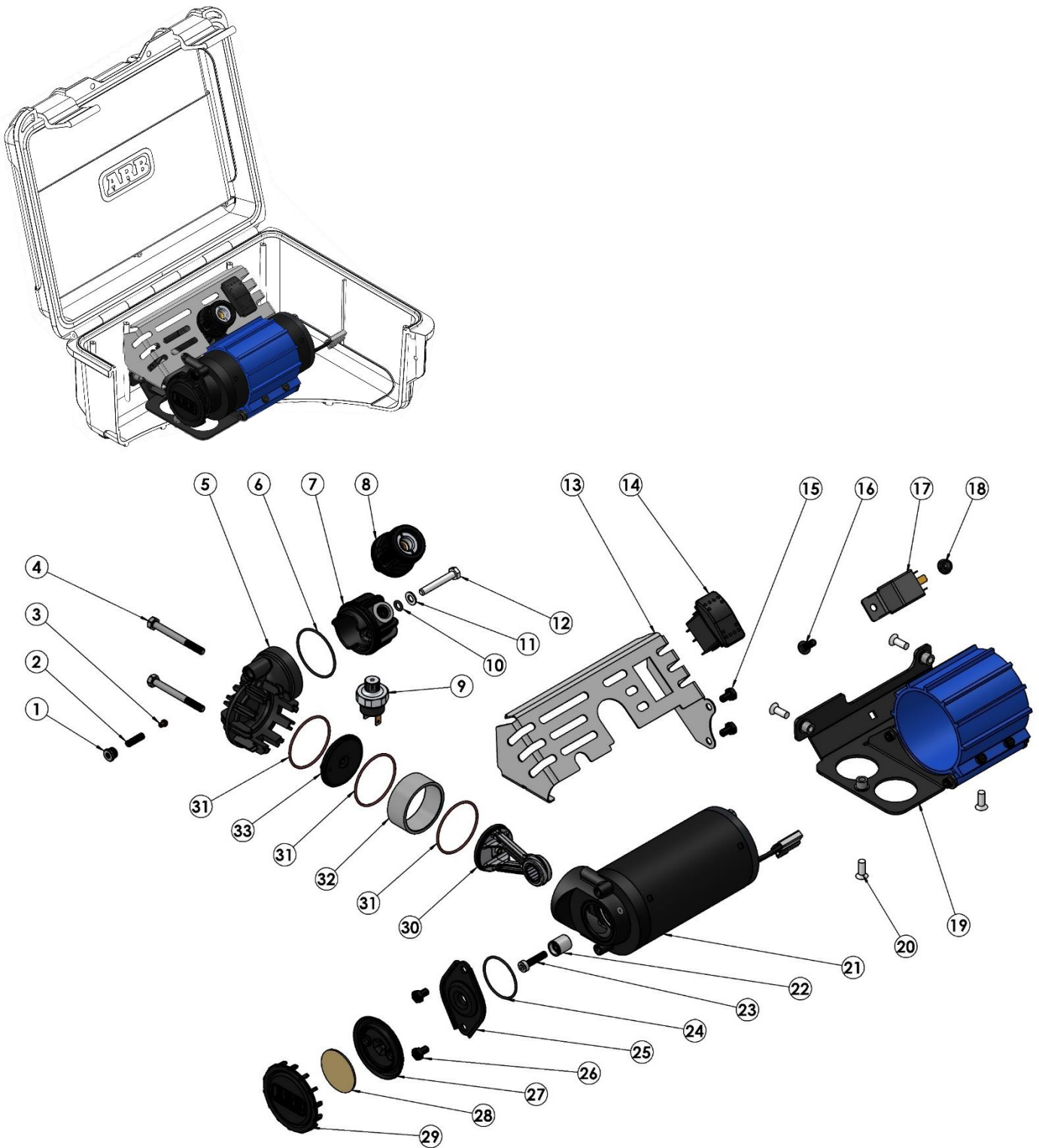

# CKMP12V2



## CKMP12V2

## Portable Compressor Kit – Exploded Parts Diagram

GENERAL SPECS	METRIC	IMPERIAL
SUPPLY VOLTAGE	12 Volts DC	12 Volts DC
MAX CURRENT DRAW	32 Amps @ 690 KPa	32 Amps @ 100 PSI
FUSE RATING (Maxi-Blade type)	40 Amps	40 Amps
RELAY RATING	40 Amps	40 Amps
WEIGHT (total kit)	7.0 Kgs	15.4 Lbs
DIMENSIONS	-LENGTH	356 mm
	-WIDTH	308 mm
	-HEIGHT	182 mm
DUTY CYCLE @ 22°C [72°F]	50 %	30 mins. per hour
PRESSURE SWITCH CLOSED	< 520 KPa	< 75 PSI
PRESSURE SWITCH OPEN	> 725 KPa	> 105 PSI
SAFETY VALVE PRESSURE	> 1035 KPa	> 150 PSI
MOTOR THERMAL CUT-OUT	115 degrees C	239 degrees F
MAX. AMBIENT TEMPERATURE	100 degrees C	212 degrees F

NO LOAD SPECS	METRIC @ 0 KPa	IMPERIAL @ 0 PSI
CURRENT DRAW	13 Amps	13 Amps
AIR FLOW RATE	75.1 L/min.	2.65 CFM

SPECS @ TYRE PRESSURE	METRIC @ 200 KPa	IMPERIAL @ 29 PSI
CURRENT DRAW	22.9 Amps	22.9 Amps
AIR FLOW RATE	61.6 L/min.	2.18 CFM

EXTERNAL CONNECTIONS SPECS	
AIR INTAKE THREAD (female)	1/4-18 NPSC (parallel pipe thread)
AIR FILTER THREAD (male)	1/4-18 NPT (tapered pipe thread)
PRESSURE SWITCH THREAD	1/4-18 NPT (tapered pipe thread)
SAFETY VALVE PORT THREAD	1/8 BSPP (parallel pipe thread)
MANIFOLD PORT THREAD	1/4-18 NPT (tapered pipe thread)
AIR COUPLING FITTING TYPE (international equivalent standards)	'US Industrial Standard' ISO 6150 B Rectus series 23/24/1400 Tema series 1400 Legris series 23 DYNAQUIP D3 CEJN 310 US.MIL.C 4109 Norma / AFNOR: NF.E49.053 Parker series 30-¼" and 20-¼" Aignep 220 Hansen series 3000 Norgren series 237 Gromelle series 600

**NOTE :** The specifications above were recorded under laboratory conditions @ 22°C [72°F].

**CKMP12V2** Air Compressor – Overview of Design Features**Description:**

---

The ARB CKMP series portable air compressor is a world class recreational product designed and built to commercial / industrial / military standards for the user who values dependability as much as performance.

**Features:**

---

- Ultra compact design makes this the highest flowing portable compressor in its class.
- Constructed entirely of light weight, high strength engineering grade materials, including military and aerospace standard components.
- Fully sealed components for moisture and dust resistance.
- Motor is 100% ball bearing equipped, and features a unique linear brush pre-load system for extra long life, low heat, and quiet operation throughout the life of the unit.
- Motor is thermal cut-out protected against damage caused by extreme temperature use.
- Pressure switch and 40 amp automotive relay equipped electrical system prevents run-on when not filling, or any damage to compressor or hoses as a result of the pressure generated from a kinked air line.
- Illuminated isolating switch is easy to see at night, and protects the user from hazardous sparking when connecting the alligator clips to the battery terminals.
- Heavy duty Maxi-Fuse equipped power leads for professional in-line circuit protection.
- Hard-anodized cylinder bore and PTFE (Teflon) impregnated carbon fiber piston seal for reduced friction and maximum trouble free life.
- Compressor piston is equipped with a German made high shock rated cylindrical roller bearing.
- High density and high flow washable sintered bronze air filter element.
- Over-pressure safety valve equipped as a back-up protection from either pressure switch failure, thermal over pressure generated in a hot vehicle (i.e., no need to drain pressure when finished use.), or accidental connection to an external high pressure source.

**Kit Includes:**

---

- Fully assembled and performance tested air compressor mounted into a waterproof and impact resistant polymer case with a handy storage pocket.
- OEM quality illuminated compressor isolating switch.
- High quality wiring loom with automotive grade alligator clamp type battery contacts, and a pressure switch driven automotive relay control circuit.
- Splash resistant air filter with washable high-flow sintered bronze filter cartridge.
- 7 meter [23 ft] long high quality abrasion and heat resistant air hose with male to female couplings.
- Hose couplings are specially designed corrosion resistant, one-handed (push-lock) quick connect type to suit US industrial standard air fittings (Ref: Section 1.3 of manual).
- Inflation accessories kit including high-flow tyre filler attachment (US industrial standard) with integral stop-valve, a Schrader valve to US industrial standard adaptor, and extra nozzle attachments for inflating items such as sports balls, air mattresses, etc.

**Optional Accessories:**

---

Pump-up hose extension (part #171301V2) – a male to female coupling equipped air hose to reach 7m [23 ft] further. (same as the hose included with CKMP12)