

ARB AIR LOCKER *Air Operated Locking Differentials*

CKMTA12 & CKMTA24

On-Board Air Compressor Kit,
Maximum Performance

ITEM #	QTY	DESCRIPTION	PART #	NOTES
01(a)	2	COMPRESSOR ASSEMBLY (12V)	CKM01	1
01(b)	2	COMPRESSOR ASSEMBLY (24V)	CKM02	1
02	1	TWIN COMPRESSOR MOUNT ASSEMBLY	320108	
03	3	O-RING (BS031N70)	160241	2
04	1	COUPLER MANIFOLD	320227	
05	2	FLAT WASHER (M6)	6151046	2
06	2	HEX BOLT (M6 x 60mm)	200703	2
07	2	O-RING (METRIC 6X2 N70)	160242	2
08	1	MANIFOLD CAP	320214	
09	1	PRESSURE SWITCH (1/4" NPT)	180901	
10	8	HEX BOLT (M6 x 12mm)	200702	
11	1	COVER ASSEMBLY, CKMT	320110	
12	2	O-RING (BS029N70)	160250	2
13	2	AIR FILTER FLANGE (1/4" NPT)	320212	
14	2	AIR FILTER COVER	320501A	2
15	2	AIR FILTER ELEMENT (DISK TYPE)	290503	2
16	2	AIR FILTER BASE	320501B	2
*	4	HEX BOLT (M6 X 20mm)	6151213	
*	4	FLAT WASHER (M6)	200709	
*	4	NYLON LOCK-NUT (M6)	6151223	
*	1	WIRING LOOM SUPPLY (CKMTA12 /24)	180414	3
*	1	WIRING LOOM SWITCH (CKMTA12 / 24)	180415	3
*	1	RELAY, SEALED (12V 40A)	180905	
*	1	SWITCH w/ COVER (12V LED)	180222SP	
*	2	FUSE,40A,MAXI TYPE	180703	
*	1	MINI BLADE FUSE HOLDER, 5A FUSE	180418	4
*	1	EYE TERMINAL,8MM (RED)	180707	4
*	1	CABLE JOINER, INSULATED (RED)	180708	4
*	1	INSTALLATION GUIDE,CKMA	2102MTA	

* Not illustrated in exploded view.

Specs:

Voltage	12 Volts (CKMTA12), 24 Volts (CKMTA24)
Current Draw	No-Load 28A (CKMTA12 only) Load 50A (CKMTA12 only)
Air Flow	174.3L/min @ 0Bar [6.16CFM @ 0psi] 131.7L/min @ 2Bar [4.65CFM @ 29psi]
Total Weight	8.8kg [19.4lbs]
Size	102mm x 190mm x 275mm (H,L,W) [4.0" x 7.5" x 10.8"]
Outlet Port	1/4" NPT
Pressure Switch	Open 10.3Bar [150psi]
Pressure Switch	Closed 9.3Bar [135psi]
Safety Valve	OPEN @ > ~12.4Bar [180 psi]

Notes:

- 1 Motor voltage is the only difference between The CKMAT12 and CKMTA24 compressors. Motor is serviceable with replacement brushes available as #320111.
- 2 Included in Complete Overhaul Kit (P/N 180914)
Two kits required for twin compressors
- 3 Wiring looms set of #180414 & #180415 suits both 12 & 24 volt systems. See full wiring diagram Attached.
- 4 Only Included in the CKMTA24

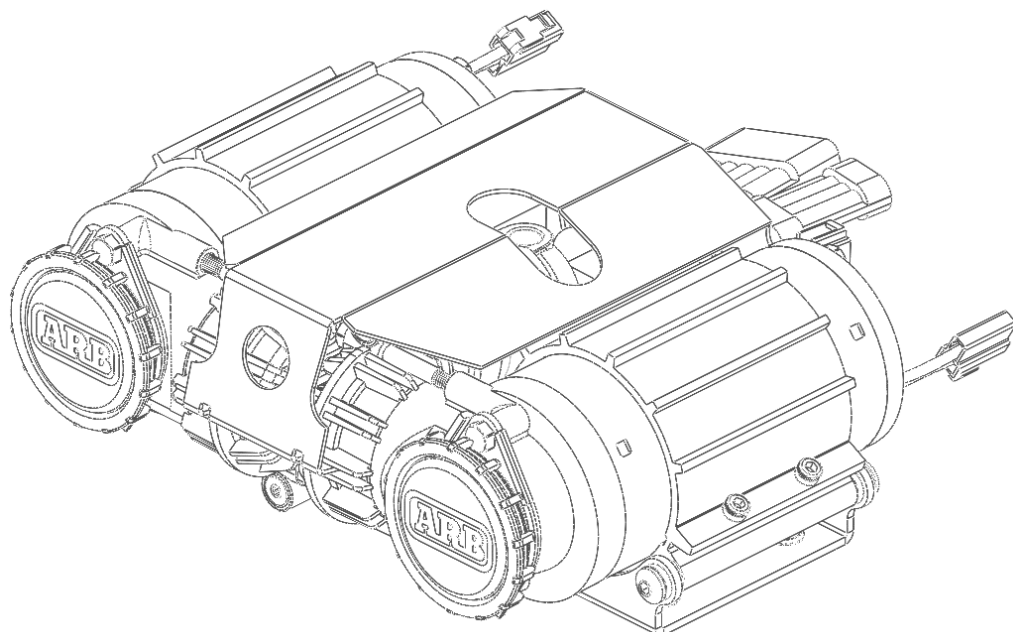

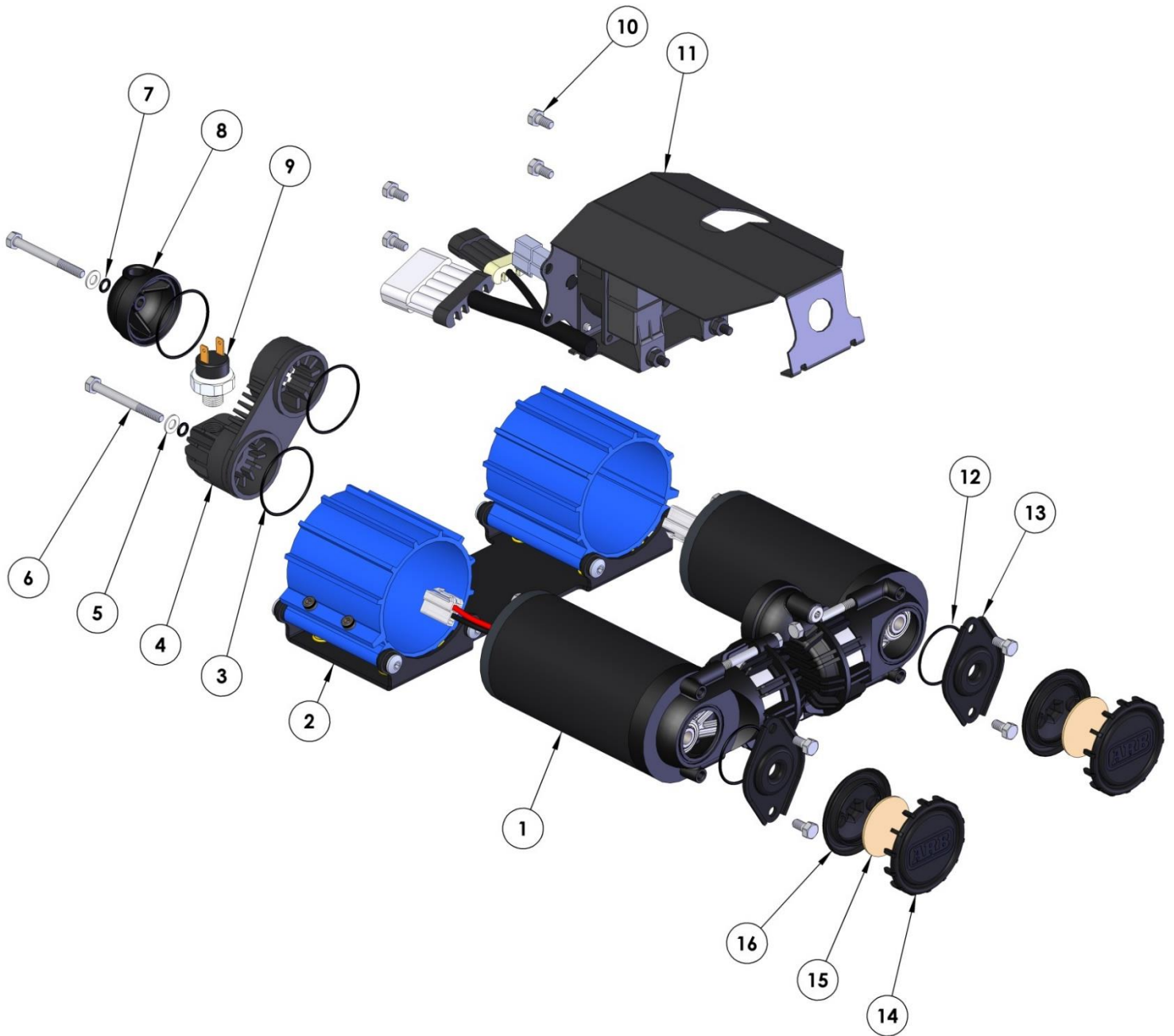

CKMTA12 & CKMTA24

ARB AIR LOCKER *Air Operated Locking Differentials*

CKMTA12 & CKMTA24 Air Compressor – Overall Sizes

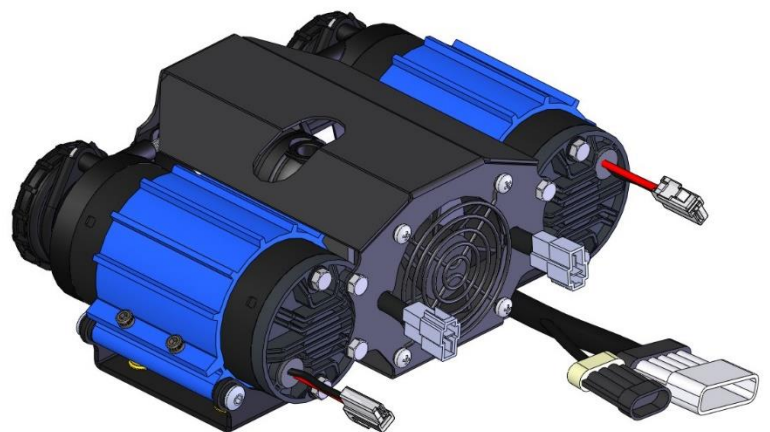
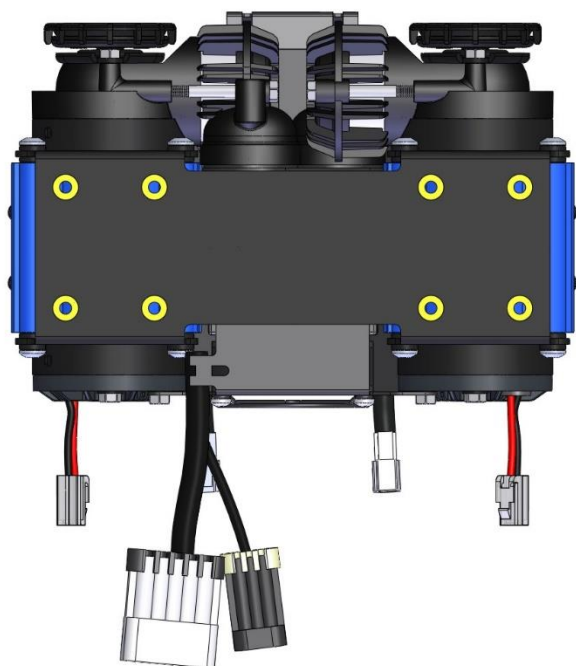
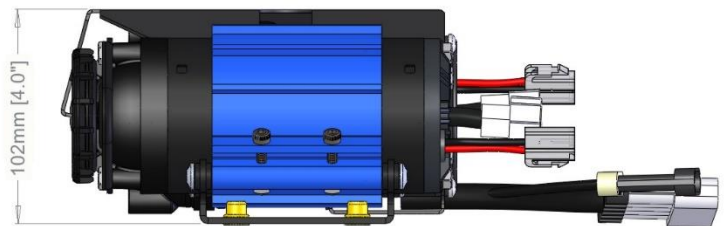
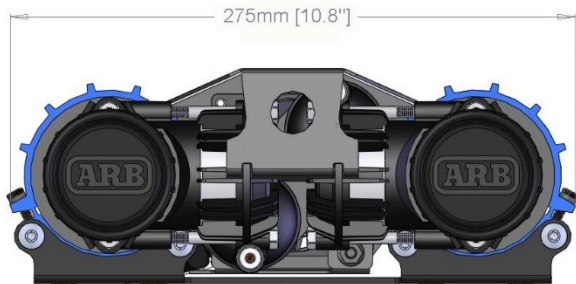
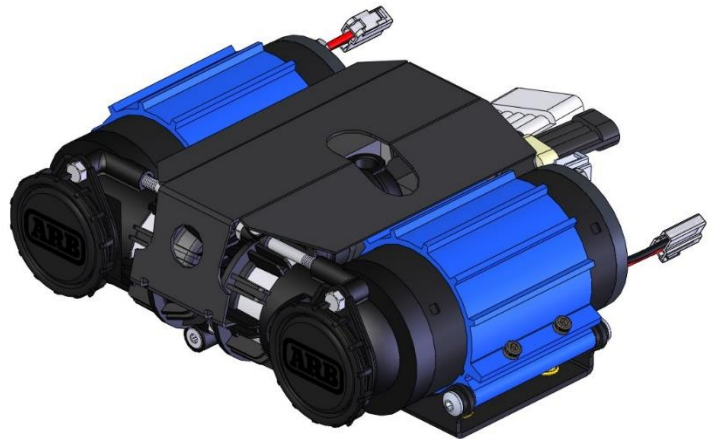

Description:

The ARB CKMTA12 and CKMTA24 twin on-board compressor kits were designed specifically as a compact sized yet high-volume compressed air source to suit the high volume airflow needs of most air powered tools, and also to suit the actuation and control needs of the ARB Air Locker, and the harsh and demanding environment of the ARB Air Locker user.

Features:

- Available in 12V (CKMTA12) or 24V (CKMTA24) models.
- Compact twin motor, dual cylinder design makes it the highest flowing compressor in its class (voltage vs. size), at 174LPM [6.16CFM] meaning it is able to fit into tight areas where other high flowing compressors will not.
- Constructed entirely of light weight, high strength, engineering grade materials, including military and aerospace standard components.
- Pressure switch controlled air manifold system regulates pressure between 930kPa [135PSI] and 1030kPa[150PSI] suited to air tools and all ARB Air Locker equipped vehicles.
- High efficiency design consumes only 56 Amps at maximum air flow.
- Built with sealed components for moisture and dust resistance.
- Hard-anodized cylinder bores and PTFE (Teflon) impregnated carbon fibre piston seals for reduced friction and maximum trouble free life.
- Ducted IP55 sealed brushless DC cooling fan and anodized motor mounting brackets effectively dissipate heat from the motors, heads and electronics allowing for a 100% duty cycle (under room temperature conditions).
- Anti-vibration / sound deadening is integrated into the mount.
- Relocatable splash resistant air filter assembly for cleaner, cooler air supply and versatile waterproof air intake positioning.
- High density and high flow washable sintered bronze air filter element.
- Full wiring loom included for simplified installation and easy plug-in connectivity to Air Locker control solenoids.
- Equipped with dual heavy duty Maxi-Fuses for professional in-line circuit protection and true circuit redundancy in case of a fault.
- Motors are water sealed, 100% ball bearing equipped (i.e. no bushings), and feature a unique linear brush pre-load system for extra long life, low heat and quiet operation throughout the life of the unit.
- Motors are internally thermal protected against extreme temperature damage.
- Compressor pistons are equipped with a European made high shock rated cylindrical roller bearing.
- Over-pressure safety valve equipped.
- Fully serviceable and all replacement parts available.
- Integrated EMC noise suppression to protect sensitive auto electronic systems.
- CKMTA12 and CKMTA24 are certified compliant to; EN 55014.1 (AS/NZS CISPR 14.1) and meets or surpasses the following Australian and European directives; 2004/108/EC – EMC directive.



Kit Includes:

- Fully assembled and tested air compressor (12V or 24V).
- Complete wiring loom w/ Air Locker solenoid plug-in contacts.
- OEM quality IP54 rated compressor isolating dash switch.
- 2 x relocatable splash resistant air filter with washable high-flow sintered bronze filter cartridge.
- Mounting bolts and washers.
- Comprehensive photo illustrated installation guide.

