

# ARB AIR LOCKER *Air Operated Locking Differentials*

## CKMTP12 & CKMTP24

## Portable Air Compressor

## Specs:

ITEM #	QTY	DESCRIPTION	PART #	NOTES
01	1	CARRY CASE	270104	
02	1	HOSE ASSEMBLY, TANK INPUT	170305	
03	8	SCREW (COUNTERSUNK M6 x 16)	200715	
04	1	TWIN COMPRESSOR MOUNT ASSEMBLY	320108	
05	2	BOLT (M6 x 60mm)	200703	2
06	2	FLAT WASHER	6151046	2
07	2	O-RING (BS010V75)	160242	2
08	1	MANIFOLD CAP (1/4" NPT)	320214	
09	1	ADAPTER (1/4" NPT TO JIC-4)	170631	
10(a)	2	COMPRESSOR ASSEMBLY (12V)	CKM01	1
10(b)	2	COMPRESSOR ASSEMBLY (24V)	CKM02	1
11	2	AIR FILTER BASE	320501B	2
12	2	AIR FILTER ELEMENT (DISK TYPE)	290503	2
13	2	AIR FILTER COVER	320501A	2
14	8	BOLT (M6 x 12mm)	200702	
15	2	AIR FILTER FLANGE (1/4" NPT)	320212	
16	2	O-RING (BS029N70)	160250	2
17	3	O-RING (BS031N70)	160241	2
18	1	COUPLER MANIFOLD	320227	
19	1	PRESSURE SWITCH (1/4" NPT)	180901	
20(a)	1	COVER ASSEMBLY, CKMTP12	320109	3
20(b)	1	COVER ASSEMBLY, CKMTP24	320112	3
21	1	SWITCH BRACKET, CKMTP	320230	
22	1	HOSE COUPLING (US STD FEMALE)	171403	
23	1	SWITCH w/ COVER (12V LED)	180222SP	
24	1	CARRY CASE POCKET	270105	
25	1	HOSE ASSEMBLY, TANK OUTPUT	170306	
26	1	AIR TANK	171501	
*	1	INFLATION ACCESSORY KIT (US STD)	171303	
*	1	HOSE ASSEMBLY (US STD)	171301	
*	1	AIR BLOW GUN	171309	
*	1	WIRING LOOM (CKMTP12 SUPPLY)	180412	
*	1	WIRING LOOM (CKMTP12 SWITCH)	180413	

Voltage	12V DC	24V DC
Current Draw	No-Load	28.4A
	Load	50.4A
Air Flow	174.4L/min @ 0kPa [6.16CFM @ 0psi]	
	131.8L/min @ 200kPa [4.68CFM @ 29psi]	
Total Weight	15kg [33lbs]	
Size	186mm x 478mm x 355mm (H,L,W) [7.3" x 18.8" x 14"]	
Outlet	Hose coupling, US std female	
Pressure Switch	Open	1030kPa [150psi]
	Closed	930kPa [135psi]
Safety Valve	Open @ > ~1240kPa [180 PSI]	

## Notes:

- 1 Motor voltage is the only difference between the CKM01 and CKM02 compressor sub-assemblies.
- 2 Included in Complete Overhaul Kit (P/N 180914)  
Two kits required for twin compressors
- 3 CKMTP12 cover assembly is preassembled with a wiring loom, 12V relays #CO42 and 12V fan #180801. CKMTP24 cover assembly is preassembled with a wiring loom, 24V relays #CO41 and 24V fan #180802.

\* Not illustrated in exploded view.

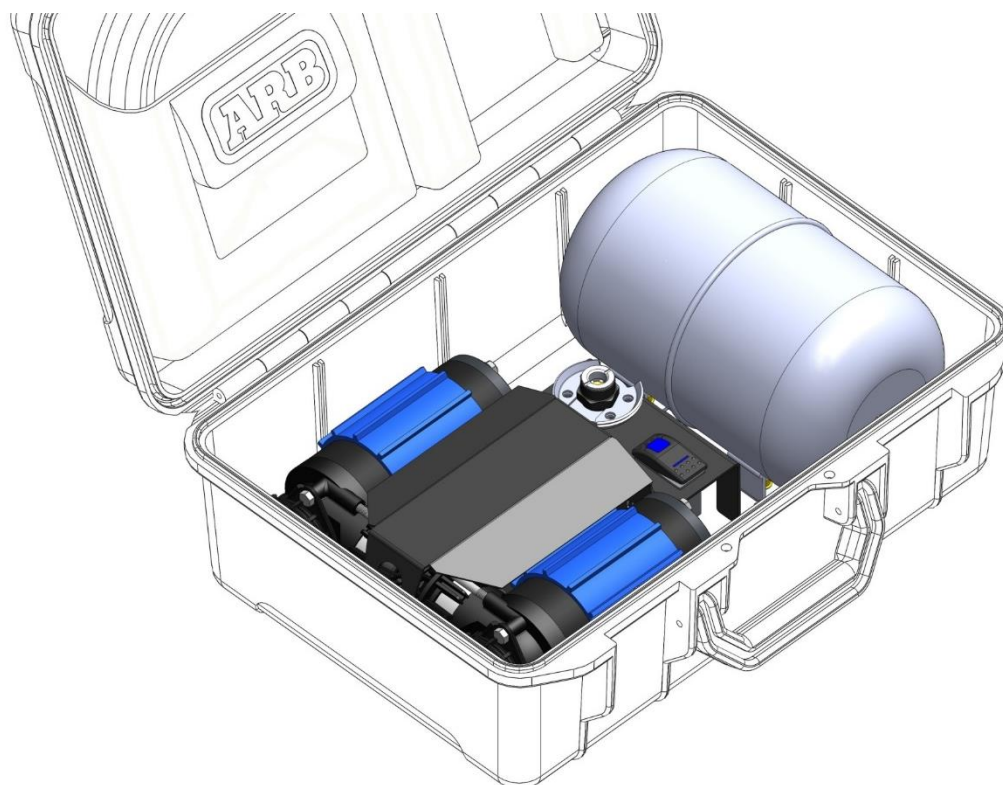

# ARB AIR LOCKER *Air Operated Locking Differentials*

## **CKMTP12 & CKMTP24** Portable Air Compressor – Exploded Parts Diagram

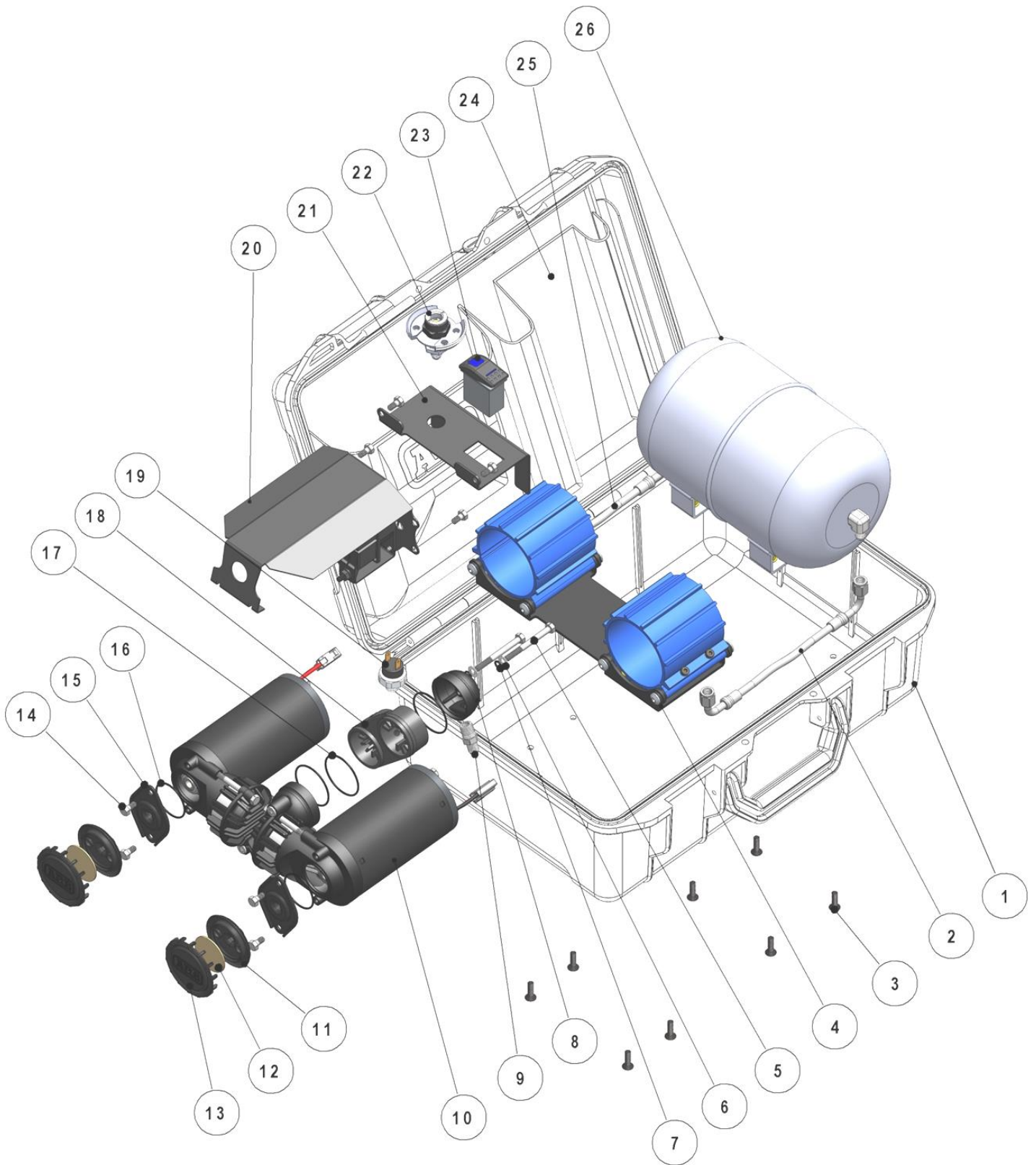

# **CKMTP12 & CKMTP24**



POWER SPECS	CKMTP12		CKMTP24	
SUPPLY VOLTAGE	12	Volts DC	24	Volts DC
MAX CURRENT DRAW (each motor)	34.3	Amps @ 1030 kPa	17.2	Amps @ 1030 kPa
MAX CURRENT DRAW (total)	68.6	Amps @ 1030 kPa	34.3	Amps @ 1030 kPa
FUSE RATING (each motor)	40	Amps	40	Amps
RELAY RATING (each motor)	40	Amps	30	Amps

GENERAL SPECS CKMT12/24	METRIC		IMPERIAL	
WEIGHT (total kit)	15	kg	33	lb
DIMENSIONS	-LENGTH	478	mm	18.8
	-WIDTH	355	mm	14.0
	-HEIGHT	186	mm	7.3
DUTY CYCLE @ 22°C [72°F]	100	%	60	minutes per hour
PRESSURE SWITCH CLOSED	< 930	kPa	< 135	PSI
PRESSURE SWITCH OPEN	> 1030	kPa	> 150	PSI
SAFETY VALVE PRESSURE	> 1240	kPa	> 180	PSI
MOTOR THERMAL CUT-OUT	115	°C	239	°F
MAX. AMBIENT TEMPERATURE	100	°C	212	°F

SPECS @ NO LOAD	METRIC		IMPERIAL	
TEST PRESSURE	0	kPa	0	PSI
CURRENT DRAW CKMTP12	28.4	Amps	28.4	Amps
CURRENT DRAW CKMTP24	14.2	Amps	14.2	Amps
AIR FLOW RATE	174.4	L/min.	6.16	CFM

SPECS @ TYRE PRESSURE	METRIC		IMPERIAL	
TEST PRESSURE	200	kPa	29	PSI
CURRENT DRAW CKMTP12	50.4	Amps	50.4	Amps
CURRENT DRAW CKMTP24	25.2	Amps	25.2	Amps
AIR FLOW RATE	131.8	L/min.	4.68	CFM

**NOTE:** The specifications above were recorded under laboratory conditions at 22°C [72°F].

EXTERNAL CONNECTIONS SPECS	
AIR INTAKE THREADS (female)	1/4-18 NPSC (parallel pipe thread)
AIR FILTER THREAD (male)	1/4-18 NPT (tapered pipe thread)
PRESSURE SWITCH THREAD	1/4-18 NPT (tapered pipe thread)
SAFETY VALVE PORT THREAD	1/8 BSPP (parallel pipe thread)
MANIFOLD OUTLET THREAD	1/4-18 NPT (tapered pipe thread)
STAINLESS BRAIDED HOSES	JIC-4 [AN-4]
AIR COUPLING FITTING TYPE (international equivalent standards)	‘US Industrial Standard’ ISO 6150 B, US.MIL.C 4109, Legris series 23, Rectus series 23/24/1400, Tema series 1400, DYNAQUIP D3, CEJN 310, Norma / AFNOR: NF.E49.053, Parker series 30-1/4” and 20-1/4”, Aignep 220, Hansen series 3000, Norgren series 237, Gromelle series 600

### WARRANTY

This ARB Air Compressor is designed to provide many years of trouble free recreational use, and is warranted to be free from manufacturing defects for two (2) years from the date of purchase.

### Description:

The ARB CKMTP twin portable compressor was specifically designed as a compact sized yet high performance compressed air source for rapid inflation of large tires, and to suit the high volume airflow needs of most air powered tools. The ARB twin portable compressor is a world class recreational product designed and built to commercial / industrial standards to survive harsh and demanding outback conditions.

### Features:

- Compact twin motor, dual cylinder design makes it the highest flowing portable compressor of its size on the market at 174LPM [6.16CFM].
- Constructed entirely of light weight, high strength engineering grade materials, including military and aerospace standard components.
- Integrated aluminium air tank and pressure switch regulates pressure between 930kPa [135PSI] and 1030kPa [150PSI] suited to most air powered tools.
- Mounted in a waterproof carry case constructed from a durable impact resistant polymer. The carry case has convenient compartments for storing the air hose and other compressor accessories.
- Built with sealed components for moisture and dust resistance.
- Hard-anodized cylinder bores and PTFE (Teflon) impregnated carbon fibre piston seals for reduced friction and maximum trouble free life.
- Ducted IP55 sealed brushless DC cooling fan and anodized motor mounting brackets effectively dissipate heat from the motors, heads and electronics allowing for a 100% duty cycle (under room temperature conditions).
- Anti-vibration / sound deadening is integrated into the mount.
- High density and high flow washable sintered bronze air filter element.
- Pressure switch and relay equipped electrical system prevents run-on when not filling, or any damage to compressor or hoses as a result of the pressure generated from a kinked air line.
- Illuminated isolating switch is easy to see at night, and protects the user from hazardous sparking when connecting the alligator clips to the battery terminals.
- Equipped with dual heavy duty Maxi-Fuses for professional in-line circuit protection and true circuit redundancy in case of a fault.
- Motors are water sealed, 100% ball bearing equipped (i.e. no bushings), and feature a unique linear brush pre-load system for extra long life, low heat and quiet operation throughout the life of the unit.
- Motors are internally thermal protected against extreme temperature damage.
- Compressor pistons are equipped with a European made high shock rated roller bearing.
- Over-pressure safety valve equipped as back-up protection from either pressure switch failure, thermal over pressure generated in a hot vehicle (i.e., no need to drain pressure when finished use), or accidental connection to an external high pressure source.
- Fully serviceable and all replacement parts available.
- Hose couplings are specially designed corrosion resistant, one-handed (push-lock) quick connect type to suit US Industrial Standard air fittings (Ref: compatible types listed in detailed specs).
- Integrated EMC noise suppression to protect sensitive auto electronic systems.
- CKMTP is certified compliant to; EN 55014.1 (AS/NZS CISPR 14.1) and meets or surpasses the following Australian and European directives; 2004/108/EC – EMC directive.



# **ARB AIR LOCKER** *Air Operated Locking Differentials*

## **Kit Includes:**

---

- Fully assembled and tested air compressor and air tank mounted into a water proof carry case.
- Canvas compartment for storing air hose and compressor accessories.
- Complete wiring loom with automotive grade alligator clamp type battery contacts, and a pressure switch driven automotive relay control circuit.
- OEM quality IP54 rated illuminated compressor isolating switch.
- 2 x splash resistant air filters with washable high-flow sintered bronze filter cartridges.
- 6 meter [20 ft] long high quality abrasion and heat resistant air hose with male to female couplings.
- Air blow gun with US industrial standard male air fitting.
- Inflation accessories kit including high-flow tyre filler attachment (US industrial standard) with integral stop-valve, a Schrader valve to US industrial standard adaptor, and extra nozzle attachments for inflating items such as sports balls, air mattresses, etc.
- Comprehensive photo illustrated operating instructions.

## **Optional Accessories:**

---

ARB offers a range of accessories to help maximize the potential of your ARB CKMTP twin portable compressor.

- ARB605 - **Inflation/deflation gauge (stainless braided, lock-on)**
- ARB606 - **Tyre inflator wand (long reach, push-on)**
- ARB607 - **Tyre inflator chuck (angled, lock-on)**
- 171301 - 6m [20ft] high temperature inflation hose with US Industrial Standard M/F air couplings (for additional length requirements)