

ARB AIR LOCKER *Air Operated Locking Differentials*

170102 Bulkhead Fitting Kit, 5mm to 3/16"

ITEM #	QTY	DESCRIPTION	PART #	NOTES
01	-	AIR LINE (5mm NYLON)	170301	1
02	1	OUTER COMPRESSION NUT (5mm)	170602	
03	1	FERRULE (5mm)	170603	3
04	1	AIRLINE SUPPORT TUBE (5mm)	170601	
05	1	CNTRL COMPRESSION NUT (5mm to 3/16")	170604	
06	1	BULKHEAD BODY	170605	
07	1	FERRULE (3/16")	170606	3
08	1	INNER COMPRESSION NUT (3/16")	170607	
09	-	AIR LINE (3/16" STEEL)	N/A	2
*	1	BULKHEAD JUNCTION SUPPORT SPRING	170701	

Specs:

External Tube Size 5mm
Internal Tube Size 3/16"
Bulkhead Thread 1/4" NPT

Notes:

- 1 Air line is not included with the bulkhead kit.
- 2 Air line is from seal housing.
- 3 Ferrules can be distinguished by the ID and thickness of the outer band (refer to diagram).

* Not illustrated in exploded view.

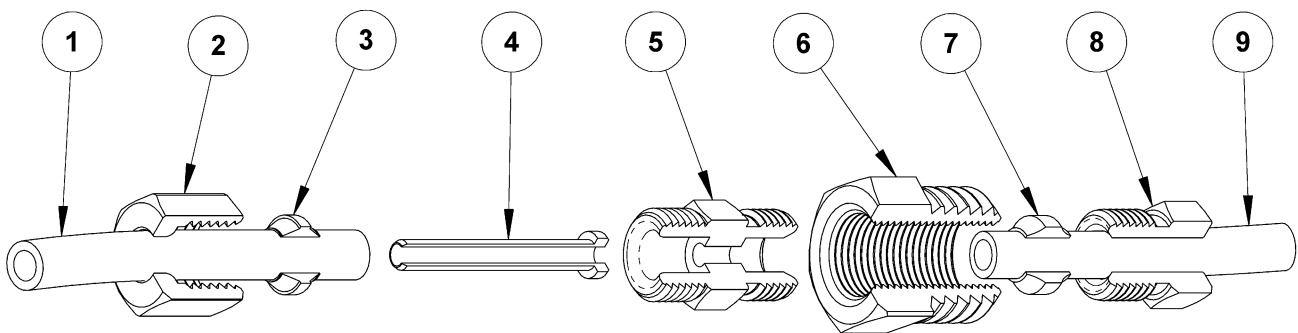

170103 Bulkhead Fitting Kit, 5mm to 1/8"

ITEM #	QTY	DESCRIPTION	PART #	NOTES
01	-	AIR LINE (5mm NYLON)	170301	1
02	1	OUTER COMPRESSION NUT (5mm)	170602	
03	1	FERRULE (5mm)	170603	3
04	1	AIRLINE SUPPORT TUBE (5mm)	170601	
05	1	CNTRL COMPRESSION NUT (5mm to 1/8")	170608	
06	1	BULKHEAD BODY	170605	
07	1	FERRULE (1/8")	170609	3
08	1	INNER COMPRESSION NUT (1/8")	170610	
09	-	AIR LINE (1/8" STEEL)	N/A	2
*	1	BULKHEAD JUNCTION SUPPORT SPRING	170701	

Specs:

External Tube Size 5mm
Internal Tube Size 1/8"
Bulkhead Thread 1/4" NPT

Notes:

- 1 Air line is not included with the bulkhead kit.
- 2 Air line is from seal housing.
- 3 Ferrules can be distinguished by the ID and thickness of the outer band (refer to diagram).

* Not illustrated in exploded view.

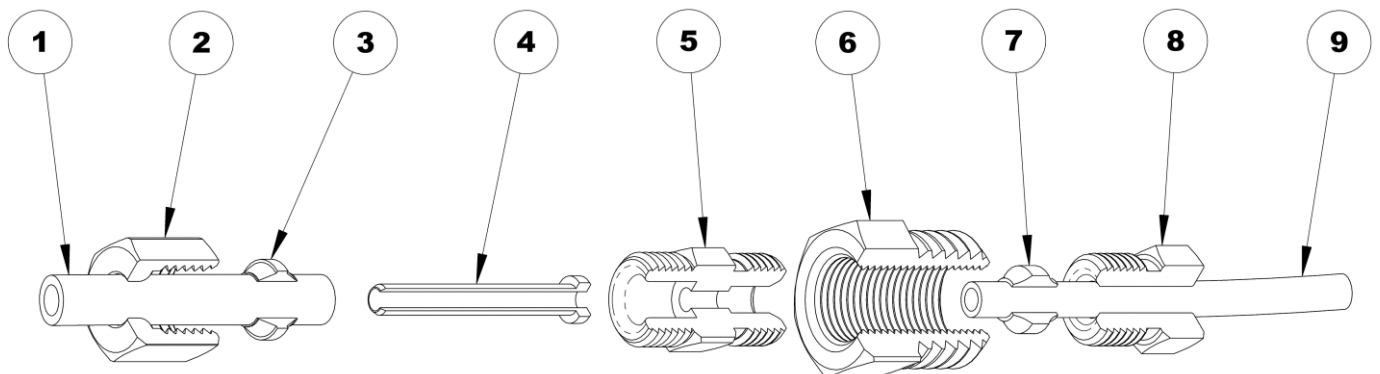

ARB AIR LOCKER *Air Operated Locking Differentials*

170105 Bulkhead Fitting Kit, 3.5mm O-ring type

ITEM #	QTY	DESCRIPTION	PART #	NOTES
01	-	AIR LINE (5mm NYLON)	170301	1
02	1	OUTER COMPRESSION NUT (5mm)	170602	
03	1	FERRULE (5mm)	170603	
04	1	AIRLINE SUPPORT TUBE (5mm)	170601	
05	1	CNTRL COMPRESSION NUT (5 to 3.5mm)	170615	
06	1	O-RING (BS104N70)	160234	2
07	1	BULKHEAD BODY (3.5mm O-RING TYPE)	170611	
08	-	AIR LINE (3.5mm COPPER)	N/A	3
*	1	BULKHEAD JUNCTION SUPPORT SPRING	170701	

* Not illustrated in exploded view.

Specs:

External Tube Size 5mm
Internal Tube Size 3.5mm
Bulkhead Thread 1/4" NPT

Notes:

- 1 Air line is not included with the bulkhead kit.
- 2 For replacement O-ring use BS104 Nitrile 70.
- 3 Air line is from seal housing.

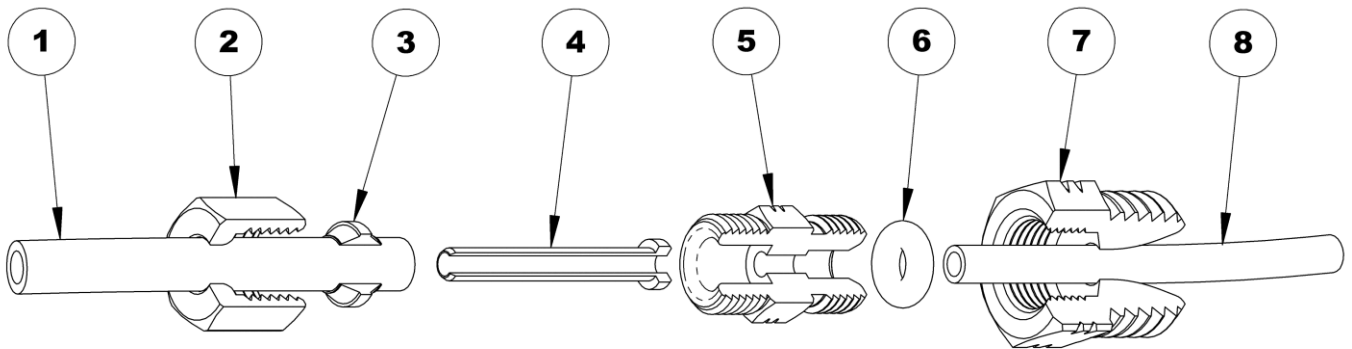

170108 Bulkhead Fitting Kit, 5 to 3.5mm

ITEM #	QTY	DESCRIPTION	PART #	NOTES
01	-	AIR LINE (5mm NYLON)	170301	1
02	1	OUTER COMPRESSION NUT (5mm)	170602	
03	1	FERRULE (5mm)	170603	3
04	1	AIRLINE SUPPORT TUBE (5mm)	170601	
05	1	CNTRL COMPRESSION NUT (5 to 3.5mm)	170615	
06	1	BULKHEAD BODY	170605	
07	1	FERRULE (3.5mm)	170614	3
08	1	INNER COMPRESSION NUT (3.5mm)	170613	
09	-	AIR LINE (3.5mm COPPER)	N/A	2
*	1	BULKHEAD JUNCTION SUPPORT SPRING	170701	

* Not illustrated in exploded view.

Specs:

External Tube Size 5mm
Internal Tube Size 3.5mm
Bulkhead Thread 1/4" NPT

Notes:

- 1 Air line is not included with the bulkhead kit.
- 2 Air line is from seal housing.
- 3 Ferrules can be distinguished by the ID and markings on the outer band (refer to diagram).

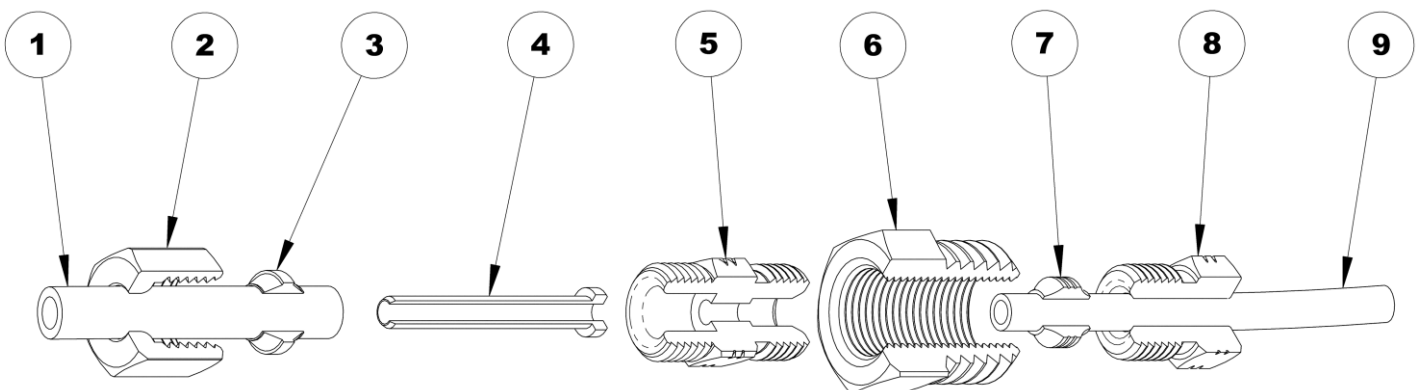

ARB AIR LOCKER *Air Operated Locking Differentials*

170109 Air Junction Kit, 3.5mm to 3.5mm

ITEM #	QTY	DESCRIPTION	PART #	NOTES
01	1	AIR LINE (3.5mm COPPER, 250mm LONG)	170406	
02	2	OUTER COMPRESSION NUT (3.5mm)	170612	
03	2	FERRULE (3.5mm)	170614	
04	1	CNTRL COMPRESSION NUT (3.5 to 3.5mm)	170616	
05	-	EXISTING AIR LINE (3.5mm COPPER)	N/A	1

Specs:

Tube Size 3.5mm

Notes:

- 1 Only one 250mm length of air line is supplied.

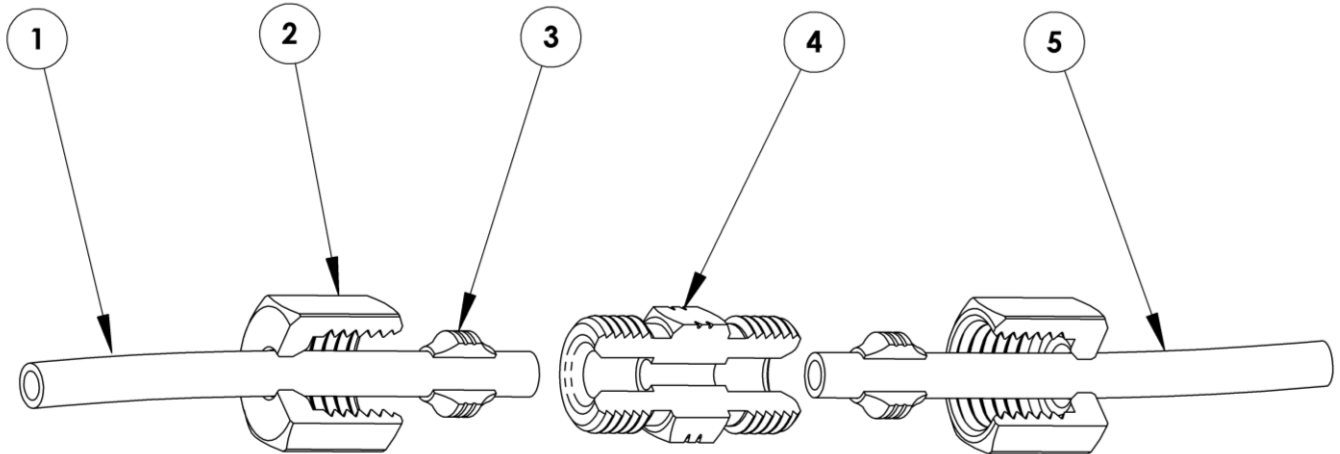

170111 Bulkhead Fitting Kit, 3.5mm O-ring type

ITEM #	QTY	DESCRIPTION	PART #	NOTES
01	-	AIR LINE (5mm NYLON)	170301	1
02	1	OUTER COMPRESSION NUT (5mm)	170661	
03	1	CNTRL COMPRESSION NUT (5 to 3.5mm)	170660	
04	1	O-RING (BS104N70)	160234	2
05	1	BULKHEAD BODY (3.5mm O-RING TYPE)	170611	
06	1	AIR LINE (3.5mm COPPER)	N/A	3
*	1	BULKHEAD JUNCTION SUPPORT SPRING	170701	

Specs:

External Tube Size 5mm
Internal Tube Size 3.5mm
Bulkhead Thread 1/4" NPT

Notes:

- 1 Air line is not included with the bulkhead kit.
- 2 For replacement O-ring use BS104 Nitrile 70.
- 3 Air line is from seal housing.

* Not illustrated in exploded view.

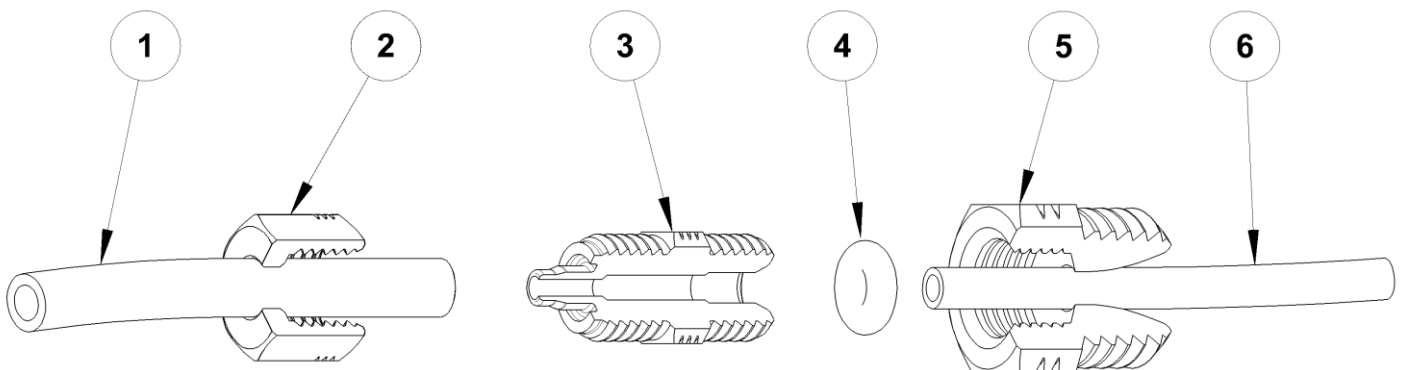

ARB AIR LOCKER *Air Operated Locking Differentials*

170114 Bulkhead Fitting Kit, 3.5mm O-ring type

ITEM #	QTY	DESCRIPTION	PART #	NOTES
01	1	BANJO BOLT	***	
02	2	BANJO WASHER	***	
03	1	BANJO ELBOW (1/8" BSP)	***	
04	1	COMPRESSION FITTING BODY (6mm)	SEE NOTE	4
05	1	OUTER COMPRESSION NUT (6mm)	SEE NOTE	4
06	-	AIRLINE (6mm)	170314	1
07	1	FERRULE (6mm)	SEE NOTE	4
08	1	CENTER COMPRESSION NUT (6 to 3.5mm)	***	
09	1	SPACER	***	
10	1	O-RING (BS006 N90)	160256	2
11	1	BULKHEAD BODY	***	
12	1	AIRLINE (3.5mm COPPER)	N/A	3
*	1	PUSH IN FITTING 6mm	170213	

Specs:

External Tube Size 6mm
 Internal Tube Size 3mm
 Bulkhead Thread 1/4" NPT

Notes:

- 1 Air line is not included with the bulkhead kit.
- 2 Available as 10 O-ring packet #160256.
- 3 Air line is from seal housing.
- 4 Available as complete fitting #170214. Ferrule also available separate as #170632.
- 5 To aid install 6mm x M5 elbow #170216 and 6mm x 1/8 BSPP elbow #170217 also available.

* Not illustrated in exploded view.

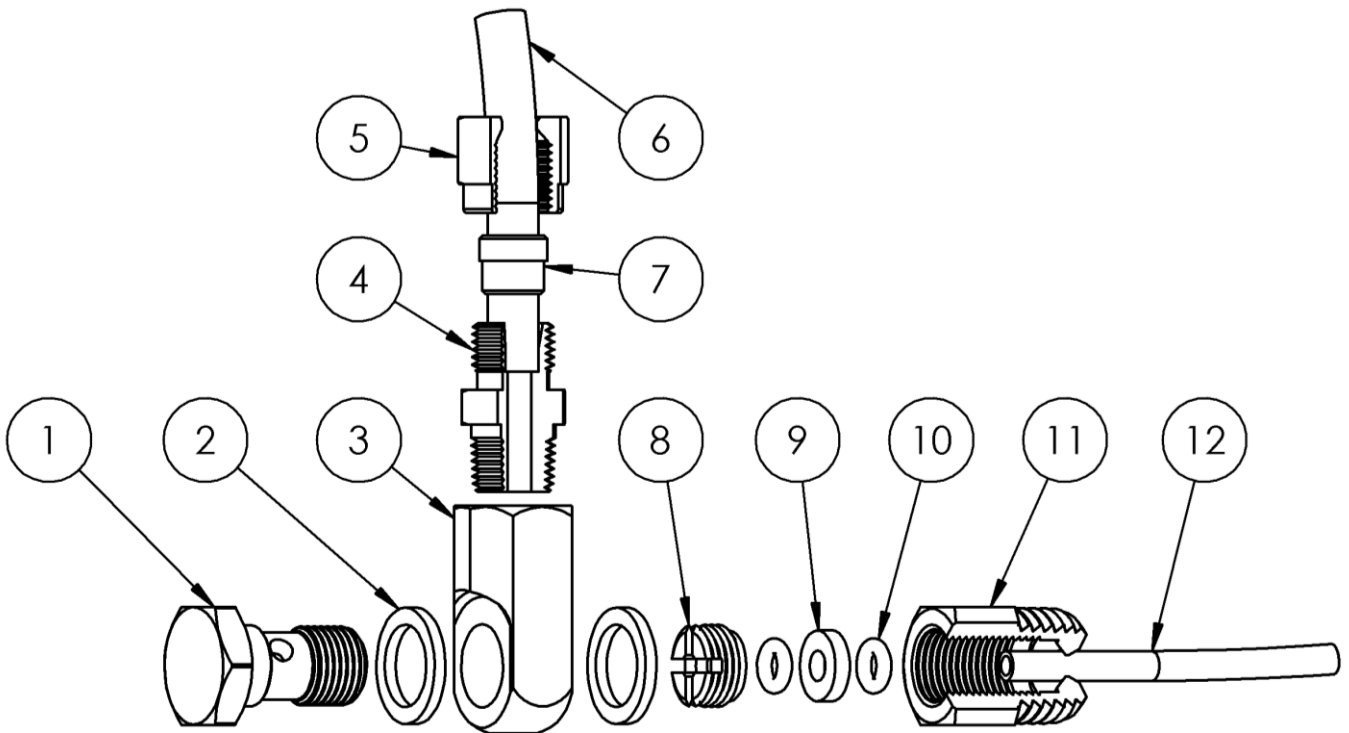

ARB AIR LOCKER *Air Operated Locking Differentials*

ASK001 Air Line Service Kit, 5mm

ITEM #	QTY	DESCRIPTION	PART #	NOTES
01	-	EXISTING AIR LINE (5mm NYLON)	N/A	1
02	2	CONNECTOR (5mm)	170206	
03	1	AIR LINE (5mm DIA X 2m LONG)	170302	
*	1	O-RING (BS104N70)	160234	

Specs:

Tube Size 5mm

Notes:

1 Only one 2 meter length of air line is supplied.

* Not illustrated in exploded view.

