

5.6 RING & PINION GEAR MODIFICATIONS

PINION FACE CLEARANCE

Some aftermarket pinion gears (and occasionally some factory pinion gears) extend so far towards the differential centre that they make contact with the body of the Air Locker. If this is the case then the end of the pinion gear will have to be carefully ground or machined away until at least 0.5mm [0.020"] of clearance exists.

NOTE : If less than 0.5mm [0.020"] of clearance exists between the pinion gear and the Air Locker then contact could still be made when the assembly flexes under high torque.

Before making any modifications to the overall length of the pinion gear you should first record the pinion depth (usually marked on the end of the pinion) and then add the amount removed to this depth and mark it on the pinion as the new pinion depth. Never attempt to modify the Air Locker to create clearance as this would weaken the Air Locker. Removing material from the very end of the pinion gear will not harm the ring and pinion set since this portion of the pinion gear does not come in contact with the teeth of the ring gear.

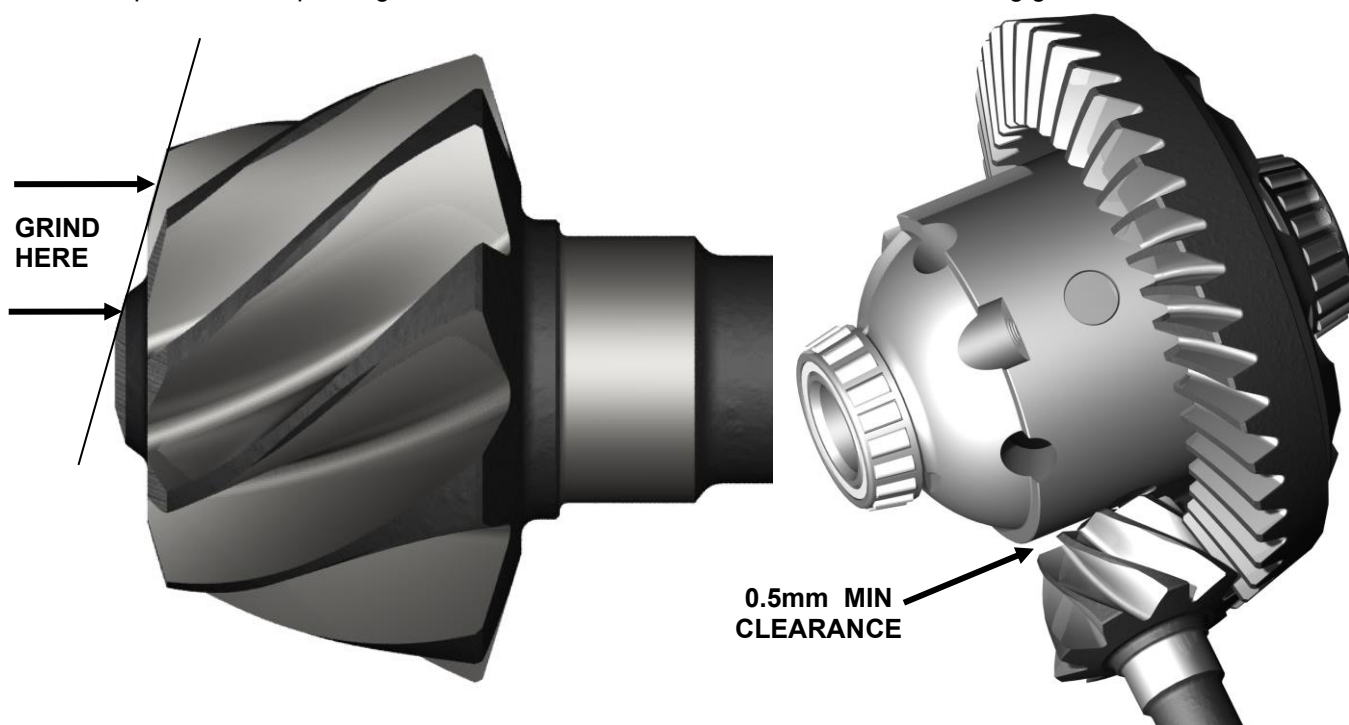

RING GEAR CROSS SHAFT RELIEF

In the case of C-clip differentials, the long cross shaft of the Air Locker must be removed to install the C-clips which retain the axles. Using aftermarket ring & pinion sets that are numerically higher than the original ratio (e.g., changing from 3.56:1 to 4.88:1) can sometimes mean that one of the ring gear teeth will block the path of the cross shaft. NEVER MODIFY THE CROSS SHAFT TO CORRECT THIS PROBLEM. Simply grind a small relief into the ring gear tooth directly across from the cross shaft hole as shown below. A small relief of this type will not affect the strength of the ring gear.

