

### RD222

### GM 8.5"/10 Bolt/AAM 860, 30 SPL

#### PARTS LIST

ITEM #	QTY	DESCRIPTION	PART #	NOTES
1	1	SPLINED SIDE GEAR	SEE NOTE	3
2	1	SHORT CROSS SHAFT	060403SP	
3	1	SPIDER BLOCK	070902SP	
4	1	LONG CROSS SHAFT	060204SP	
5	1	SIDE GEAR	SEE NOTE	3
6	2	SIDE GEAR THRUST WASHER	SEE NOTE	4
7	1	COUNTERSUNK SCREW (PK OF 2)	200213SP	
8	1	RETAINING PIN SET (PK OF 4)	120601SP	
9A	1	SHIM KIT (Ø73.0 [2.9"])	SHK003	
9B	1	SHIM KIT (Ø77.8 [3.1"])	SHK008	
10	2	TAPERED ROLLER BEARING (OD 73.43mm)	160114	2
11A	1	SEAL HOUSING BRACKET (SALISBURY)	220217	
11B	1	SEAL HOUSING BRACKET (BANJO)	220216	
12	1	SEAL HOUSING KIT	081817SP	
13	1	SEAL HOUSING O-RING (PK OF 2)	160248-2	1
14	1	FLANGE CAP KIT	028404SP	
15	1	BONDED SEAL	160702SP	
16	1	CLUTCH GEAR & WAVESPRING KIT	050901SP	
17	1	WAVESPRING	150701SP	
18	3	PINION GEAR	SEE NOTE	3
19	3	PINION THRUST WASHER	SEE NOTE	4
20	1	DIFFERENTIAL CASE	013003SP	
*	1	C-CLIP KIT	CCK005	
*	1	AIR LINE (6mm DIA X 6m LONG)	170314	5
*	1	BULKHEAD FITTING KIT (BANJO TYPE)	170114	5
*	1	SOLENOID VALVE (12V)	180103	
*	1	CABLE TIE (PK OF 25)	180305	
*	1	SWITCH/RR LOCKER	180224	
*	1	OPERATING & SERVICE MANUAL	210200	
*	1	INSTALLATION GUIDE	2102222	

\* *Not illustrated in exploded view*

#### NOTES

- 1 For replacement O-rings use only BS140 Viton 75.
- 2 For replacement bearing on early model 'small bearing' (Ø73.43mm [2.891"]) axle use Timken part # LM102949 / LM102911.  
For replacement bearing on late model 'large bearing' (Ø77.79mm [3.063"]) axle use Timken part # LM603049 / LM603012.
- 3 Available only as complete 5 gear set #728H051C
- 4 Available only as complete thrust washer kit #730H01
- 5 All diffs produced before serial #17070001 came with 5mm air connection system. For information contact ARB.
- Ring gear bolts are 7/16" - 20 left-hand thread, and must be removed in a clockwise direction.
- Thicker aftermarket ring gears may require modification to remove the cross shaft. Refer to tech note ([Section 5.6](#)).
- For the 28 spline model see RD221 ([Section 2.221](#)).

**RD222**

GM 8.5"/10 Bolt/AAM 860, 30 SPL

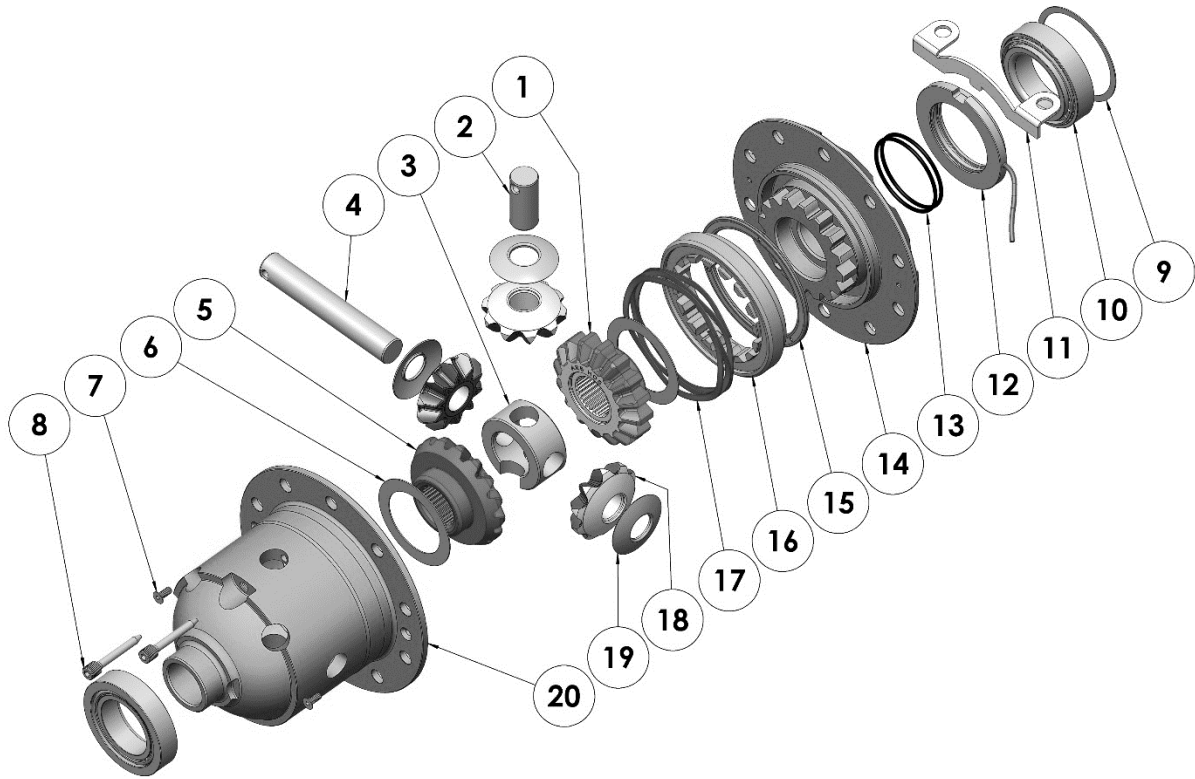
**EXPLODED DIAGRAM****SPECIFICATIONS**

Axle Spline	30 tooth, Ø33.3mm [1.31"]
Ratio Supported	2.73:1 & up
Ring Gear ID	127.0mm [5.00"]
Ring Gear OD	216mm [8.5"] & 219mm [8.63"]
Ring Gear Bolts	10 bolts on Ø156mm [6.14"]
Ring Gear Torque	88Nm [65 ft-lb] (GM 8.5") 108Nm [80 ft-lb] (AAM 860)
Backlash	0.15-0.25mm [0.006-0.010"]
Bearing Cap Torque	81Nm [60 ft-lb] (GM 8.5") 108Nm [80ft-lb] (AAM 860)

ARB Corporation Ltd ▪ 42-44 Garden St Kilsyth VIC 3137 Australia  
ARB 4X4 Accessories USA ▪ 4810 D St. NW #103 Auburn WA 98001 USA  
Australia & International Customer Service ▪ +61 3 9761 6622  
North America Customer Service ▪ Toll Free 866 293 9078  
www.arb.com.au (AUS & Int) www.arbusa.com (N. America)